

**SECTION BR**  
**BRAKE SYSTEM**

A  
B  
C  
D  
E

**CONTENTS**

<b>SYMPTOM DIAGNOSIS</b> .....	<b>3</b>	<b>DISC ROTOR</b> .....	<b>16</b>	<b>BR</b>
		DISC ROTOR : Inspection .....	16	
<b>NOISE, VIBRATION AND HARSHNESS (NVH) TROUBLESHOOTING</b> .....	<b>3</b>	<b>REAR DISC BRAKE</b> .....	<b>17</b>	<b>G</b>
NVH Troubleshooting Chart .....	3	<b>BRAKE PAD</b> .....	<b>17</b>	
		BRAKE PAD : Inspection .....	17	
<b>PRECAUTION</b> .....	<b>4</b>	<b>DISC ROTOR</b> .....	<b>17</b>	<b>H</b>
		DISC ROTOR : Inspection .....	17	
<b>PRECAUTIONS</b> .....	<b>4</b>	<b>REMOVAL AND INSTALLATION</b> .....	<b>18</b>	<b>I</b>
Precaution for Supplemental Restraint System (SRS) "AIR BAG" and "SEAT BELT PRE-TENSIONER" .....	4	<b>BRAKE PEDAL</b> .....	<b>18</b>	
Precaution Necessary for Steering Wheel Rotation after Battery Disconnect .....	4	Exploded View .....	18	<b>J</b>
Precaution for Procedure without Cowl Top Cover.....	5	Removal and Installation .....	18	
Precaution for Brake System .....	5	Inspection and Adjustment .....	19	
<b>PREPARATION</b> .....	<b>7</b>	<b>BRAKE PIPING</b> .....	<b>20</b>	<b>K</b>
		<b>FRONT</b> .....	<b>20</b>	
<b>PREPARATION</b> .....	<b>7</b>	FRONT : Exploded View .....	20	<b>L</b>
Commercial Service Tool .....	7	FRONT : Hydraulic Piping .....	21	
<b>PERIODIC MAINTENANCE</b> .....	<b>8</b>	FRONT : Removal and Installation .....	21	<b>M</b>
		FRONT : Inspection .....	22	
<b>BRAKE PEDAL</b> .....	<b>8</b>	<b>REAR</b> .....	<b>22</b>	<b>N</b>
Inspection and Adjustment .....	8	REAR : Exploded View .....	23	
<b>BRAKE FLUID</b> .....	<b>12</b>	REAR : Hydraulic Piping .....	23	<b>O</b>
Inspection .....	12	REAR : Removal and Installation .....	24	
Draining .....	12	REAR : Inspection .....	24	
Refilling .....	12	<b>BRAKE MASTER CYLINDER</b> .....	<b>25</b>	<b>P</b>
Bleeding Brake System .....	13	<b>2WD</b> .....	<b>25</b>	
<b>BRAKE MASTER CYLINDER</b> .....	<b>14</b>	2WD : Exploded View .....	25	<b>P</b>
Inspection .....	14	2WD : Removal and Installation .....	25	
<b>BRAKE BOOSTER</b> .....	<b>15</b>	2WD : Disassembly and Assembly .....	26	<b>P</b>
Inspection .....	15	2WD : Inspection .....	27	
<b>FRONT DISC BRAKE</b> .....	<b>16</b>	<b>AWD</b> .....	<b>27</b>	<b>P</b>
		AWD : Exploded View .....	28	
<b>BRAKE PAD</b> .....	<b>16</b>	AWD : Removal and Installation .....	28	<b>P</b>
BRAKE PAD : Inspection .....	16	AWD : Disassembly and Assembly .....	29	

**BR**

**G**

**H**

**I**

**J**

**K**

**L**

**M**

**N**

**O**

**P**

AWD : Inspection .....	30	<b>REAR DISC BRAKE .....</b>	<b>50</b>
<b>BRAKE BOOSTER .....</b>	<b>31</b>	<b>BRAKE PAD (FRONT CALIPER 1 PISTON TYPE)...</b>	<b>50</b>
<b>2WD .....</b>	<b>31</b>	BRAKE PAD (FRONT CALIPER 1 PISTON	
2WD : Exploded View .....	31	TYPE) : Exploded View .....	50
2WD : Removal and installation .....	31	BRAKE PAD (FRONT CALIPER 1 PISTON	
2WD : Inspection and Adjustment .....	32	TYPE) : Removal and Installation .....	50
<b>AWD .....</b>	<b>33</b>	BRAKE PAD (FRONT CALIPER 1 PISTON	
AWD : Exploded View .....	33	TYPE) : Inspection and Adjustment .....	51
AWD : Removal and installation .....	33	<b>BRAKE PAD (FRONT CALIPER 2 PISTON TYPE)...</b>	<b>51</b>
AWD : Inspection and Adjustment .....	34	BRAKE PAD (FRONT CALIPER 2 PISTON	
<b>VACUUM LINES .....</b>	<b>36</b>	TYPE) : Exploded View .....	52
Exploded View .....	36	BRAKE PAD (FRONT CALIPER 2 PISTON	
Removal and Installation .....	36	TYPE) : Removal and Installation .....	52
Inspection .....	36	BRAKE PAD (FRONT CALIPER 2 PISTON	
<b>FRONT DISC BRAKE .....</b>	<b>38</b>	TYPE) : Inspection and Adjustment .....	53
<b>BRAKE PAD (1 PISTON TYPE) .....</b>	<b>38</b>	<b>BRAKE CALIPER ASSEMBLY (FRONT CALIPER</b>	
BRAKE PAD (1 PISTON TYPE) : Exploded View...	38	<b>1 PISTON TYPE) .....</b>	<b>53</b>
BRAKE PAD (1 PISTON TYPE) : Removal and In-		BRAKE CALIPER ASSEMBLY (FRONT CALI-	
stallation .....	38	PER 1 PISTON TYPE) : Exploded View .....	54
BRAKE PAD (1 PISTON TYPE) : Inspection and		BRAKE CALIPER ASSEMBLY (FRONT CALI-	
Adjustment .....	39	PER 1 PISTON TYPE) : Removal and Installation...	54
<b>BRAKE PAD (2 PISTON TYPE) .....</b>	<b>40</b>	BRAKE CALIPER ASSEMBLY (FRONT CALI-	
BRAKE PAD (2 PISTON TYPE) : Exploded View...	40	PER 1 PISTON TYPE) : Disassembly and Assem-	
BRAKE PAD (2 PISTON TYPE) : Removal and In-		bly .....	55
stallation .....	40	BRAKE CALIPER ASSEMBLY (FRONT CALI-	
BRAKE PAD (2 PISTON TYPE) : Inspection and		PER 1 PISTON TYPE) : Inspection and Adjust-	
Adjustment .....	41	ment .....	56
<b>BRAKE CALIPER ASSEMBLY (1 PISTON TYPE)...</b>	<b>41</b>	<b>BRAKE CALIPER ASSEMBLY (FRONT CALIPER</b>	
BRAKE CALIPER ASSEMBLY (1 PISTON TYPE)		<b>2 PISTON TYPE) .....</b>	<b>57</b>
: Exploded View .....	42	BRAKE CALIPER ASSEMBLY (FRONT CALI-	
BRAKE CALIPER ASSEMBLY (1 PISTON TYPE)		PER 2 PISTON TYPE) : Exploded View .....	58
: Removal and Installation .....	42	BRAKE CALIPER ASSEMBLY (FRONT CALI-	
BRAKE CALIPER ASSEMBLY (1 PISTON TYPE)		PER 2 PISTON TYPE) : Removal and Installation...	58
: Disassembly and Assembly .....	43	BRAKE CALIPER ASSEMBLY (FRONT CALI-	
BRAKE CALIPER ASSEMBLY (1 PISTON TYPE)		PER 2 PISTON TYPE) : Disassembly and Assem-	
: Inspection and Adjustment .....	44	bly .....	59
<b>BRAKE CALIPER ASSEMBLY (2 PISTON TYPE)...</b>	<b>45</b>	BRAKE CALIPER ASSEMBLY (FRONT CALI-	
BRAKE CALIPER ASSEMBLY (2 PISTON TYPE)		PER 2 PISTON TYPE) : Inspection and Adjust-	
: Exploded View .....	45	ment .....	61
BRAKE CALIPER ASSEMBLY (2 PISTON TYPE)		<b>SERVICE DATA AND SPECIFICATIONS</b>	
: Removal and Installation .....	46	<b>(SDS) .....</b>	<b>63</b>
BRAKE CALIPER ASSEMBLY (2 PISTON TYPE)		<b>SERVICE DATA AND SPECIFICATIONS</b>	
: Disassembly and Assembly .....	47	<b>(SDS) .....</b>	<b>63</b>
BRAKE CALIPER ASSEMBLY (2 PISTON TYPE)		General Specifications .....	63
: Inspection and Adjustment .....	48	Brake Pedal .....	63
		Brake Booster .....	63
		Front Disc Brake .....	64
		Rear Disc Brake .....	64

# NOISE, VIBRATION AND HARSHNESS (NVH) TROUBLESHOOTING

< SYMPTOM DIAGNOSIS >

## SYMPTOM DIAGNOSIS

### NOISE, VIBRATION AND HARSHNESS (NVH) TROUBLESHOOTING

#### NVH Troubleshooting Chart

INFOID:000000001832348

Use the chart below to help you find the cause of the symptom. If necessary, repair or replace these parts.

Symptom		Possible cause and SUSPECTED PARTS		Reference page
BRAKE	Noise	×	Pads - damaged	BR-16, BR-17
	Shake	×	Pads - uneven wear	BR-16, BR-17
	Shimmy, Judder	×	Shims damaged	BR-41, BR-51, BR-53
		×	Rotor imbalance	BR-16, BR-17
		×	Rotor damage	BR-16, BR-17
		×	Rotor runout	BR-16, BR-17
		×	Rotor deformation	BR-16, BR-17
		×	Rotor deflection	BR-16, BR-17
		×	Rotor rust	BR-16, BR-17
		×	Rotor thickness variation	BR-16, BR-17
			Drum out of round	NVH in PB section
		×	PROPELLER SHAFT	NVH in DLN section
		×	DIFFERENTIAL	NHV in DLN section
		×	AXLE AND SUSPENSION	NVH in FAX, RAX and FSU, RSU section
		×	TIRE	NVH in WT section
		×	ROAD WHEEL	NVH in WT section
		×	DRIVE SHAFT	NVH in FAX and/or RAX section
		×	STEERING	NVH in ST section

x: Applicable

A  
B  
C  
D  
E  
BR  
G  
H  
I  
J  
K  
L  
M  
N  
O  
P

# PRECAUTIONS

< PRECAUTION >

## PRECAUTION

### PRECAUTIONS

#### Precaution for Supplemental Restraint System (SRS) "AIR BAG" and "SEAT BELT PRE-TENSIONER"

INFOID:000000002946528

The Supplemental Restraint System such as "AIR BAG" and "SEAT BELT PRE-TENSIONER", used along with a front seat belt, helps to reduce the risk or severity of injury to the driver and front passenger for certain types of collision. This system includes seat belt switch inputs and dual stage front air bag modules. The SRS system uses the seat belt switches to determine the front air bag deployment, and may only deploy one front air bag, depending on the severity of a collision and whether the front occupants are belted or unbelted. Information necessary to service the system safely is included in the "SRS AIR BAG" and "SEAT BELT" of this Service Manual.

#### **WARNING:**

- To avoid rendering the SRS inoperative, which could increase the risk of personal injury or death in the event of a collision which would result in air bag inflation, all maintenance must be performed by an authorized NISSAN/INFINITI dealer.
- Improper maintenance, including incorrect removal and installation of the SRS, can lead to personal injury caused by unintentional activation of the system. For removal of Spiral Cable and Air Bag Module, see the "SRS AIR BAG".
- Do not use electrical test equipment on any circuit related to the SRS unless instructed to in this Service Manual. SRS wiring harnesses can be identified by yellow and/or orange harnesses or harness connectors.

#### PRECAUTIONS WHEN USING POWER TOOLS (AIR OR ELECTRIC) AND HAMMERS

#### **WARNING:**

- When working near the Air Bag Diagnosis Sensor Unit or other Air Bag System sensors with the ignition ON or engine running, DO NOT use air or electric power tools or strike near the sensor(s) with a hammer. Heavy vibration could activate the sensor(s) and deploy the air bag(s), possibly causing serious injury.
- When using air or electric power tools or hammers, always switch the ignition OFF, disconnect the battery, and wait at least 3 minutes before performing any service.

#### Precaution Necessary for Steering Wheel Rotation after Battery Disconnect

INFOID:000000002946530

#### **NOTE:**

- Before removing and installing any control units, first turn the push-button ignition switch to the LOCK position, then disconnect both battery cables.
- After finishing work, confirm that all control unit connectors are connected properly, then re-connect both battery cables.
- Always use CONSULT-III to perform self-diagnosis as a part of each function inspection after finishing work. If a DTC is detected, perform trouble diagnosis according to self-diagnosis results.

This vehicle is equipped with a push-button ignition switch and a steering lock unit.

If the battery is disconnected or discharged, the steering wheel will lock and cannot be turned.

If turning the steering wheel is required with the battery disconnected or discharged, follow the procedure below before starting the repair operation.

#### OPERATION PROCEDURE

1. Connect both battery cables.

#### **NOTE:**

Supply power using jumper cables if battery is discharged.

2. Turn the push-button ignition switch to ACC position.  
(At this time, the steering lock will be released.)
3. Disconnect both battery cables. The steering lock will remain released with both battery cables disconnected and the steering wheel can be turned.
4. Perform the necessary repair operation.

# PRECAUTIONS

## < PRECAUTION >

- When the repair work is completed, re-connect both battery cables. With the brake pedal released, turn the push-button ignition switch from ACC position to ON position, then to LOCK position. (The steering wheel will lock when the push-button ignition switch is turned to LOCK position.)
- Perform self-diagnosis check of all control units using CONSULT-III.

## Precaution for Procedure without Cowl Top Cover

INFOID:000000002946529

When performing the procedure after removing cowl top cover, cover the lower end of windshield with urethane, etc.

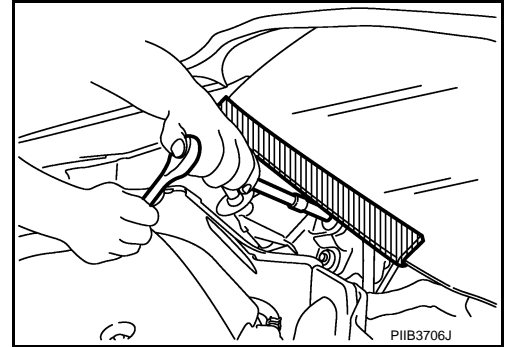

## Precaution for Brake System

INFOID:000000001832352

### **WARNING:**

Clean any dust from the front brake and rear brake with a vacuum dust collector. Never blow with compressed air.

### **CAUTION:**

- Only use "DOT 3" brake fluid. Refer to [MA-10. "Fluids and Lubricants"](#).
  - Never reuse drained brake fluid.
  - Never spill or splash brake fluid on painted surfaces. Brake fluid may seriously damage paint. Wipe it off immediately and wash with water if it gets on a painted surface.
  - After pressing the brake pedal more deeply or harder than normal driving, such as air bleeding, check each item of brake pedal. Adjust brake pedal if it is outside the standard value.
  - Always clean with new brake fluid when cleaning the master cylinder, brake caliper and other components.
  - Never use mineral oils such as gasoline or light oil to clean. They may damage rubber parts and cause improper operation.
  - Always loosen the brake tube flare nut with a flare nut wrench.
  - Tighten the brake tube flare nut to the specified torque with a crowfoot (A) and torque wrench (B).
  - Always confirm the specified tightening torque when installing the brake pipes.
  - Turn the ignition switch OFF and disconnect the ABS actuator and electric unit (control unit) connector or the battery negative terminal before performing the work.
  - Check that no brake fluid leakage is present after replacing the parts.
  - Burnish the brake contact surfaces after refinishing or replacing rotors, after replacing pads, or if a soft pedal occurs at very low mileage.
- Front brake pad (1 piston type): refer to [BR-39. "BRAKE PAD \(1 PISTON TYPE\) : Inspection and Adjustment"](#).
  - Front brake pad (2 piston type): refer to [BR-41. "BRAKE PAD \(2 PISTON TYPE\) : Inspection and Adjustment"](#).
  - Front disc rotor (1 piston type): refer to [BR-44. "BRAKE CALIPER ASSEMBLY \(1 PISTON TYPE\) : Inspection and Adjustment"](#).
  - Front disc rotor (2 piston type): refer to [BR-48. "BRAKE CALIPER ASSEMBLY \(2 PISTON TYPE\) : Inspection and Adjustment"](#).
  - Rear brake pad (front caliper 1 piston type): refer to [BR-51. "BRAKE PAD \(FRONT CALIPER 1 PISTON TYPE\) : Inspection and Adjustment"](#).
  - Rear brake pad (front caliper 2 piston type): refer to [BR-53. "BRAKE PAD \(FRONT CALIPER 2 PISTON TYPE\) : Inspection and Adjustment"](#).

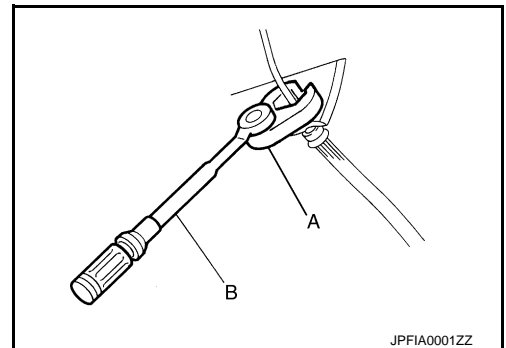

## PRECAUTIONS

< PRECAUTION >

- 
- Rear disc rotor (front caliper 1 piston type): refer to [BR-56, "BRAKE CALIPER ASSEMBLY \(FRONT CALIPER 1 PISTON TYPE\) : Inspection and Adjustment"](#).
  - Rear disc rotor (front caliper 2 piston type): refer to [BR-61, "BRAKE CALIPER ASSEMBLY \(FRONT CALIPER 2 PISTON TYPE\) : Inspection and Adjustment"](#).

# PREPARATION

< PREPARATION >

## PREPARATION

### PREPARATION

#### Commercial Service Tool

INFOID:000000001832353

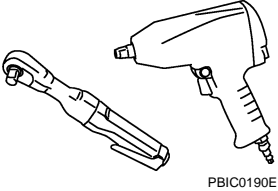
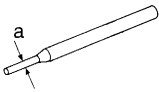
Tool name	Description
<p>Power tool</p>  <p>PBIC0190E</p>	<p>Loosening bolts and nuts</p>
<p>Pin punch a: 4 mm (0.16 in) dia.</p>  <p>NT410</p>	<p>Removing and installing reservoir tank pin</p>

A

B

C

D

E

BR

G

H

I

J

K

L

M

N

O

P

# BRAKE PEDAL

< PERIODIC MAINTENANCE >

## PERIODIC MAINTENANCE

### BRAKE PEDAL

#### Inspection and Adjustment

INFOID:000000001832355

#### INSPECTION

##### Brake Pedal Height

Check the height ( $H_1$ ) between the dash lower panel (1) and the brake pedal upper surface.

##### Standard

Brake pedal height ( $H_1$ )

: Refer to [BR-63, "Brake Pedal"](#)

##### CAUTION:

Remove the floor trim.

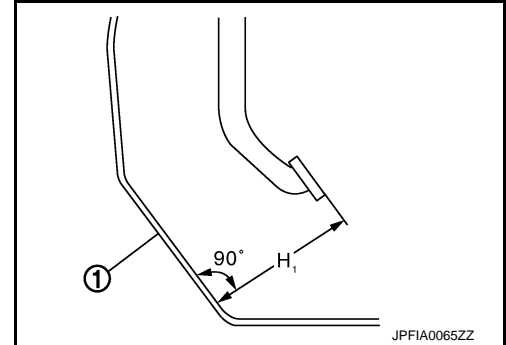

##### ASCD Brake Switch and Stop Lamp Switch

Check the clearance ( $C_1$  and  $C_2$ ) among ASCD brake switch (1) threaded end, stop lamp switch (2) threaded end and the stopper rubber (3).

##### Standard

Clearance ( $C_1$ ) between ASCD brake switch threaded end and the stopper rubber

: Refer to [BR-63, "Brake Pedal"](#)

Clearance ( $C_2$ ) between the stop lamp switch threaded end and the stopper rubber

: Refer to [BR-63, "Brake Pedal"](#)

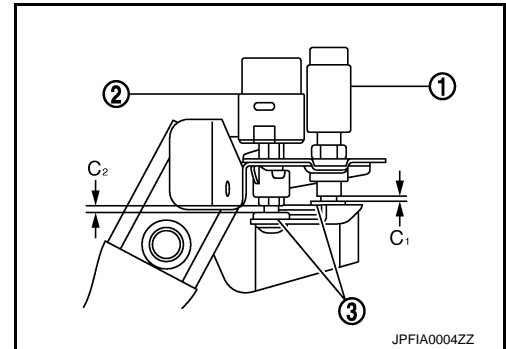

##### CAUTION:

The stop lamp must turn off when the brake pedal is released.

##### NOTE:

Pull the brake pedal pad to make the clearance between the stop lamp switch threaded end and the stopper rubber. (The stopper rubber hits ASCD brake switch threaded end.)

##### Brake Pedal Play

Press the brake pedal. Check the brake pedal play (A) (stroke until fluid pressure occurs).

##### Standard

Pedal play (A)

: Refer to [BR-63, "Brake Pedal"](#)

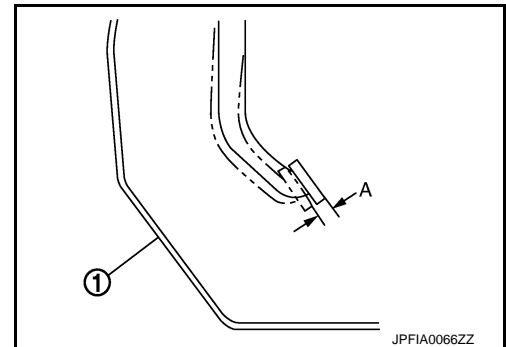

##### Brake Pedal Shaky Fitting



# BRAKE PEDAL

## < PERIODIC MAINTENANCE >

Check the brake pedal shaky fitting (B) (the stroke when pulling the brake pedal pad slightly from the free play).

### Standard

**Brake pedal shaky fitting (B)** : Refer to [BR-63, "Brake Pedal"](#)

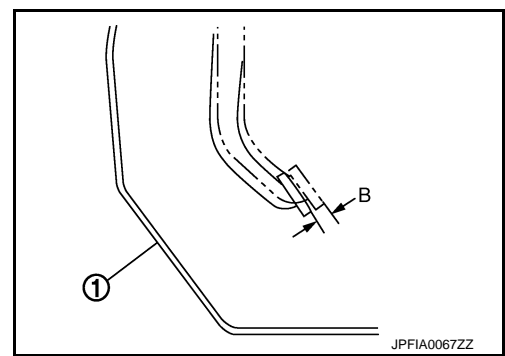

### Depressed Brake Pedal Height

Check the height between the dash lower panel (1) and the brake pedal upper surface ( $H_2$ ) when depressing the brake pedal at 490 N (50 kg, 110 lb) while turning engine ON.

### Standard

**Depressed brake pedal height ( $H_2$ )** : Refer to [BR-63, "Brake Pedal"](#)

### CAUTION:

Remove the floor trim.

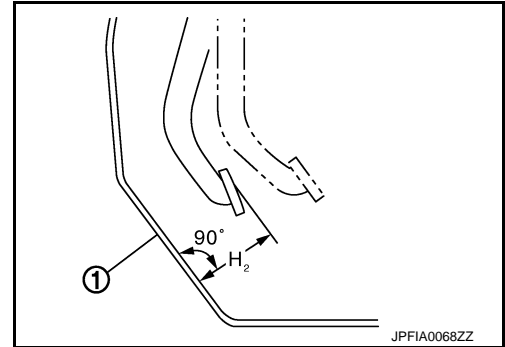

## ADJUSTMENT

### Brake Pedal Height

1. Disconnect the harness connector from ASCD brake switch and stop lamp switch.
2. Turn the stop lamp switch 45° counterclockwise.
3. Loosen ASCD brake switch lock nut. Turn ASCD brake switch counterclockwise.
4. Loosen the input rod lock nut (1). Adjust the brake pedal to the specification. Tighten the input lock nut to the specification. Refer to [BR-31, "2WD : Exploded View"](#) (2WD), [BR-33, "AWD : Exploded View"](#) (AWD).

### CAUTION:

The threaded end of the input rod must project to the inner side (L) of the clevis (3).

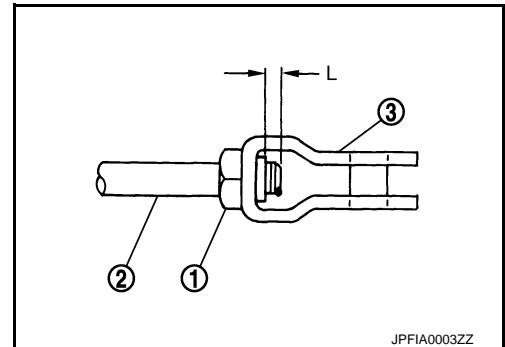

### Standard

**Brake pedal height ( $H_1$ )** : Refer to [BR-63, "Brake Pedal"](#)

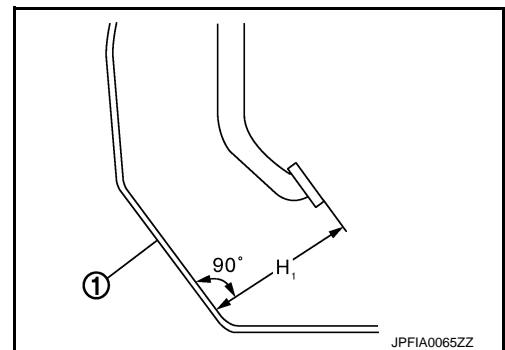

### ASCD Brake Switch and Stop Lamp Switch

1. Disconnect the harness connector from ASCD brake switch and stop lamp switch.
2. Turn the stop lamp switch 45° counterclockwise.
3. Loosen ASCD brake switch lock nut. Turn ASCD brake switch counterclockwise.

# BRAKE PEDAL

## < PERIODIC MAINTENANCE >

- Press the brake pedal pad slightly. Release the brake pedal. Turn ASCD brake switch (1) until ASCD brake switch threaded end hits to the stopper rubber (2) clockwise.

**CAUTION:**

**Never press-fit the input rod.**

- Tighten ASCD brake switch lock nut (3) to the specification. Refer to [BR-18, "Exploded View"](#).

**CAUTION:**

**The clearance (C<sub>1</sub>) between the stopper rubber and the ASCD brake switch threaded end must be the specified value. Refer to [BR-63, "Brake Pedal"](#).**

- Press-fit the stop lamp switch (4) until the stop lamp switch hits the stopper rubber 45° clockwise while pulling the brake pedal pad slightly. (ASCD brake switch threaded end hits the stopper rubber.)

**CAUTION:**

- The clearance (C<sub>2</sub>) between the stopper rubber and the stop lamp switch threaded end must be the specified value. Refer to [BR-63, "Brake Pedal"](#).**
- The stop lamp must turn off when the brake pedal is released.**

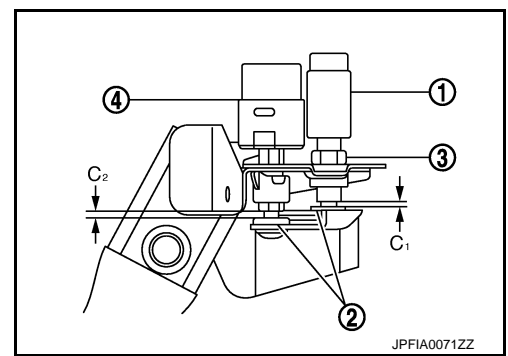

### Brake Pedal Play

- Disconnect the harness connector from ASCD brake switch and stop lamp switch.
- Turn the stop lamp switch 45° counterclockwise.
- Loosen ASCD brake switch lock nut. Turn ASCD brake switch counterclockwise.
- Press the brake pedal pad slightly. Release the brake pedal. Turn ASCD brake switch (1) until ASCD brake switch threaded end hits to the stopper rubber (2) clockwise.

**CAUTION:**

**Never press-fit the input rod.**

- Tighten ASCD brake switch lock nut (3) to the specification. Refer to [BR-18, "Exploded View"](#).

**CAUTION:**

**The clearance (C<sub>1</sub>) between the stopper rubber and the ASCD brake switch threaded end must be the specified value. Refer to [BR-63, "Brake Pedal"](#).**

- Press-fit the stop lamp switch (4) until the stop lamp switch hits the stopper rubber 45° clockwise while pulling the brake pedal pad slightly. (ASCD brake switch threaded end hits the stopper rubber.)

**CAUTION:**

- The clearance (C<sub>2</sub>) between the stopper rubber and the stop lamp switch threaded end must be the specified value. Refer to [BR-63, "Brake Pedal"](#).**
- The stop lamp must turn off when the brake pedal is released.**

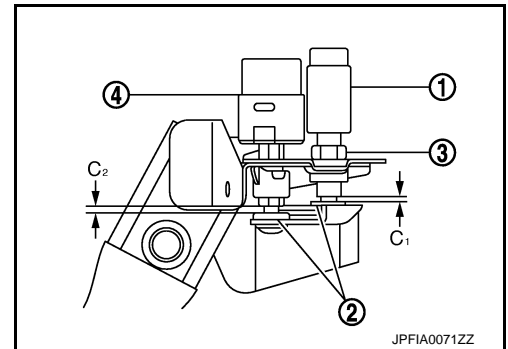

### Brake Pedal Shaky Fitting

- Disconnect the harness connector from ASCD brake switch and stop lamp switch.
- Turn the stop lamp switch 45° counterclockwise.
- Loosen ASCD brake switch lock nut. Turn ASCD brake switch counterclockwise.
- Press the brake pedal pad slightly. Release the brake pedal. Turn ASCD brake switch (1) until ASCD brake switch threaded end hits to the stopper rubber (2) clockwise.

**CAUTION:**

**Never press-fit the input rod.**

- Tighten ASCD brake switch lock nut (3) to the specification. Refer to [BR-18, "Exploded View"](#).

**CAUTION:**

**The clearance (C<sub>1</sub>) between the stopper rubber and the ASCD brake switch threaded end must be the specified value. Refer to [BR-63, "Brake Pedal"](#).**

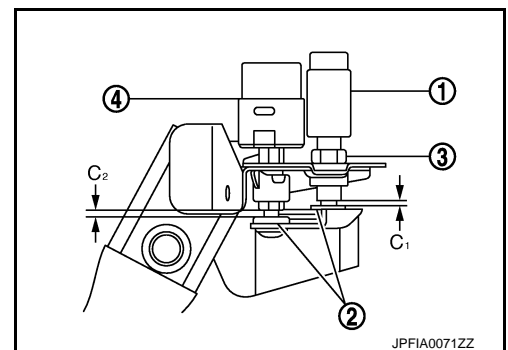

# BRAKE PEDAL

## < PERIODIC MAINTENANCE >

---

6. Press-fit the stop lamp switch (4) until the stop lamp switch hits the stopper rubber 45° clockwise while pulling the brake pedal pad slightly. (ASCD brake switch threaded end hits the stopper rubber.)

**CAUTION:**

- The clearance (C2) between the stopper rubber and the stop lamp switch threaded end must be the specified value. Refer to [BR-63, "Brake Pedal"](#).
- The stop lamp must turn off when the brake pedal is released.

A  
B  
C  
D  
E  
G  
H  
I  
J  
K  
L  
M  
N  
O  
P

BR

# BRAKE FLUID

< PERIODIC MAINTENANCE >

## BRAKE FLUID

### Inspection

INFOID:000000001832356

#### BRAKE FLUID LEVEL

- Check that the fluid level in the reservoir tank is within the specified range (MAX – MIN lines).
- Visually check for any brake fluid leakage around the reservoir tank.
- Check the brake system for any leakage if the fluid level is extremely low (lower than MIN).
- Check the brake system for fluid leakage if the warning lamp remains illuminated even after the parking brake is released.

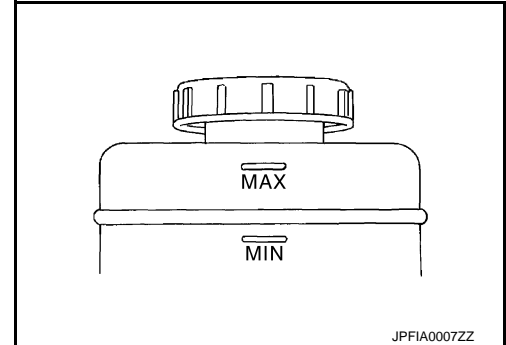

#### BRAKE LINE

1. Check brake line (tubes and hoses) for cracks, deterioration or other damage. Replace any damaged parts.
2. Check for fluid leakage by fully depressing brake pedal while engine is running.

**CAUTION:**

If leakage occurs around joints, retighten or, if necessary, replace damaged parts.

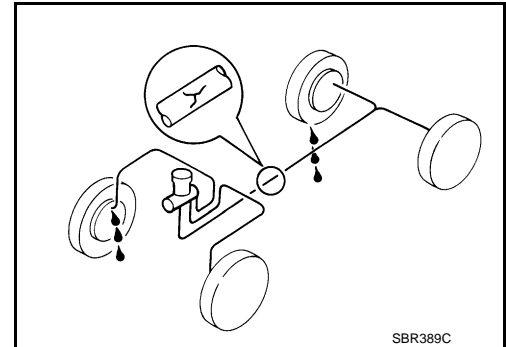

### Draining

INFOID:000000001832357

**CAUTION:**

- Never spill or splash brake fluid on painted surfaces. Brake fluid may seriously damage paint. Wipe it off immediately and wash with water if it gets on a painted surface.
- Turn the ignition switch OFF and disconnect the ABS actuator and electric unit (control unit) connector or the battery negative terminal before performing work.

1. Connect a vinyl tube to the bleed valve.
2. Depress the brake pedal and loosen the bleeder valve to gradually discharge brake fluid.

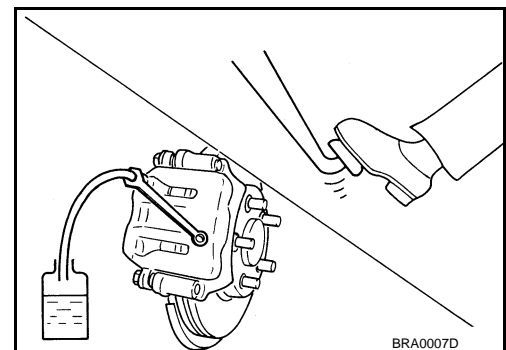

### Refilling

INFOID:000000001832358

**CAUTION:**

Turn the ignition switch OFF and disconnect the ABS actuator and electric unit (control unit) connector or the battery negative terminal before performing work.

# BRAKE FLUID

## < PERIODIC MAINTENANCE >

1. Check that there is no foreign material in the reservoir tank, and refill with new brake fluid.

**CAUTION:**

**Never reuse drained brake fluid.**

2. Loosen the bleeder valve, slowly depress the brake pedal to the full stroke, and then release the pedal. Repeat this operation at intervals of 2 or 3 seconds until all brake fluid is discharged. Then close the bleeder valve with the brake pedal depressed. Repeat the same work on each wheel.
3. Perform the air bleeding. Refer to [BR-13. "Bleeding Brake System"](#).

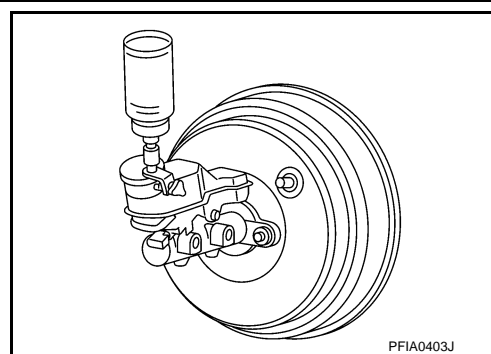

INFOID:000000001832359

## Bleeding Brake System

**CAUTION:**

- Turn the ignition switch OFF and disconnect the ABS actuator and electric unit (control unit) connector or the battery negative terminal before performing the work.
- Monitor the fluid level in the reservoir tank while performing the air bleeding
- Always use new brake fluid for refilling. Never reuse the drained brake fluid.

1. Connect a vinyl tube to the bleeder valve of the rear right brake.
2. Fully depress the brake pedal 4 to 5 times.
3. Loosen the bleeder valve and bleed air with the brake pedal depressed, and then quickly tighten the bleeder valve.
4. Repeat steps 2 and 3 until all of the air is out of the brake line.
5. Tighten the bleeder valve to the specified torque.
  - Front disc brake (1 piston type): refer to [BR-42. "BRAKE CALIPER ASSEMBLY \(1 PISTON TYPE\) : Exploded View"](#).
  - Front disc brake (2 piston type): refer to [BR-45. "BRAKE CALIPER ASSEMBLY \(2 PISTON TYPE\) : Exploded View"](#).
  - Rear disc brake (front caliper 1 piston type): refer to [BR-54. "BRAKE CALIPER ASSEMBLY \(FRONT CALIPER 1 PISTON TYPE\) : Exploded View"](#).
  - Rear disc brake (front caliper 2 piston type): refer to [BR-58. "BRAKE CALIPER ASSEMBLY \(FRONT CALIPER 2 PISTON TYPE\) : Exploded View"](#).
6. Perform steps 1 to 5 for the rear right brake → front left brake → rear left brake → and front right brake in order.
7. Check that the fluid level in the reservoir tank is within the specified range after air bleeding. Refer to [BR-12. "Inspection"](#).
8. Check each item of brake pedal. Adjust it if the measurement value is not the standard. Refer to [BR-8. "Inspection and Adjustment"](#).

# BRAKE MASTER CYLINDER

< PERIODIC MAINTENANCE >

---

## BRAKE MASTER CYLINDER

### Inspection

*INFOID:000000001832361*

### FLUID LEAK

- Check for brake fluid leakage from the master cylinder mounting face, reservoir tank mounting face and brake tube connections.

# BRAKE BOOSTER

< PERIODIC MAINTENANCE >

## BRAKE BOOSTER

### Inspection

INFOID:000000001832363

### OPERATION

Depress the brake pedal several times at 5-second intervals with the engine stopped. Start the engine with the brake pedal fully depressed. Check that the clearance between brake pedal and dash lower panel decreases.

**NOTE:**

A slight impact with a small click may be felt on the pedal when the brake pedal is fully depressed. This is a normal phenomenon due to the brake system operation.

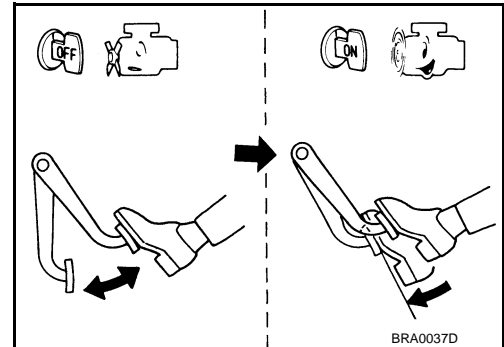

### AIR TIGHT

- Run the engine at idle for 1 minute to apply vacuum to the brake booster, and stop the engine. Then depress the brake pedal several times at 5-second intervals until the accumulated vacuum is released to atmospheric pressure. Check that the clearance between brake pedal and dash lower panel gradually increases (A → B → C) each time the brake pedal is depressed when performing this operation.

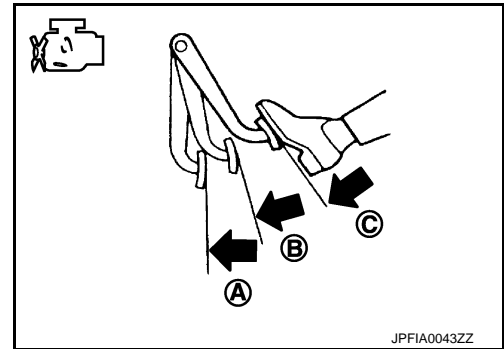

- Depress the brake pedal with the engine running. Then stop the engine while holding down the brake pedal. Check that the brake pedal stroke does not change after holding down the brake pedal for 30 seconds or more.

**NOTE:**

A slight impact with a small click may be felt on the pedal when the brake pedal is fully depressed. This is a normal phenomenon due to the brake system operation.

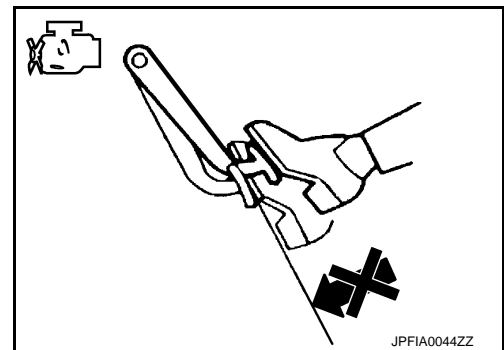

A  
B  
C  
D  
E  
BR  
G  
H  
I  
J  
K  
L  
M  
N  
O  
P

# FRONT DISC BRAKE

< PERIODIC MAINTENANCE >

## FRONT DISC BRAKE BRAKE PAD

### BRAKE PAD : Inspection

INFOID:000000001832365

#### PAD WEAR

Check pad thickness from an inspection hole on cylinder body.  
Check using a scale if necessary.

#### Standard

#### Standard thickness

: Refer to [BR-64, "Front Disc Brake"](#).

#### Limit

#### Wear limit thickness

: Refer to [BR-64, "Front Disc Brake"](#).

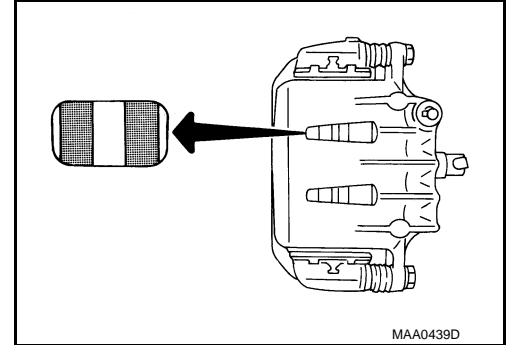

MAA0439D

## DISC ROTOR

### DISC ROTOR : Inspection

INFOID:000000001832366

#### APPEARANCE

Check surface of disc rotor for uneven wear, cracks, and serious damage. Replace if there are.

#### RUNOUT

1. Fix the disc rotor to the wheel hub and bearing assembly with wheel nuts (2 points at least).
2. Inspect the runout with a dial gauge. [Measured at 10 mm (0.39 in) inside the disc edge.]

#### Limit

#### Runout limit

: Refer to [BR-64, "Front Disc Brake"](#).

#### NOTE:

Check the wheel bearing axial end play before the inspection.  
Refer to [FAX-5, "Inspection"](#) (2WD), [FAX-14, "Inspection"](#) (AWD).

3. Find the installation position that has a minimum runout by shifting the disc rotor-to-wheel hub and bearing assembly installation position by one hole at a time if the runout exceeds the limit value.
4. Replace or lathe the disc rotor if the runout is outside the limit even after performing the above operation. [When lathing, use the Pro-Cut PEM On-Car brake Lathe (Tool No. 38-PFM90.5) or equivalent.]

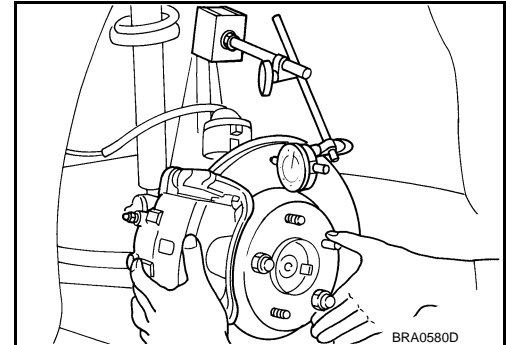

BRA0580D

#### THICKNESS

Check the thickness of the disc rotor using a micrometer. Replace the disc rotor if the thickness is below the wear limit.

#### Limit

#### Wear limit thickness

: Refer to [BR-64, "Front Disc Brake"](#).

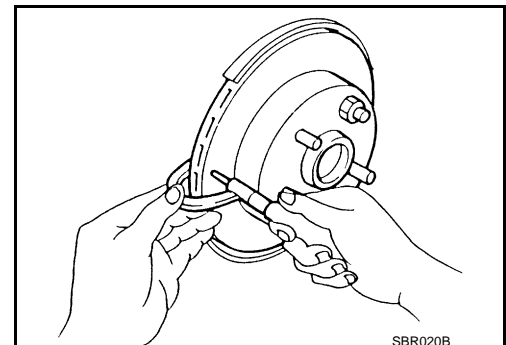

SBR020B



# REAR DISC BRAKE

< PERIODIC MAINTENANCE >

## REAR DISC BRAKE BRAKE PAD

### BRAKE PAD : Inspection

INFOID:000000001832368

#### PAD WEAR

Check pad thickness from an inspection hole on cylinder body.  
Check using a scale if necessary.

#### Standard

#### Standard thickness

: Refer to [BR-64, "Rear Disc Brake"](#).

#### Limit

#### Wear limit thickness

: Refer to [BR-64, "Rear Disc Brake"](#).

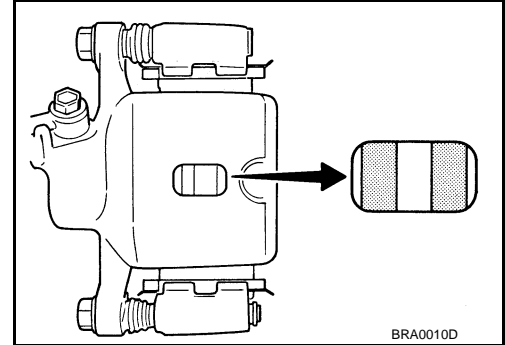

## DISC ROTOR

### DISC ROTOR : Inspection

INFOID:000000001832369

#### APPEARANCE

Check surface of disc rotor for uneven wear, cracks, and serious damage. Replace if there are.

#### RUNOUT

1. Fix the disc rotor to the wheel hub and bearing assembly with wheel nuts (2 points at least).
2. Inspect the runout with a dial gauge. [Measured at 10 mm (0.39 in) inside disc edge.]

#### Limit

#### Runout limit

: Refer to [BR-64, "Rear Disc Brake"](#).

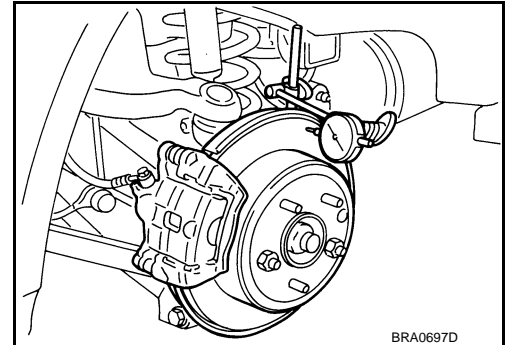

#### NOTE:

Check the wheel bearing axial end play before the inspection.  
Refer to [RAX-5, "Inspection"](#).

3. Find the installation position that has a minimum runout by shifting the disc rotor-to-wheel hub and bearing assembly installation position by one hole at a time if the runout exceeds the limit value.
4. Replace or lathe the disc rotor if the runout is outside the limit even after performing the above operation. [When lathing, use the Pro-Cut PEM On-Car brake Lathe (Tool No. 38-PFM90.5) or equivalent.]

#### THICKNESS

Check the thickness of the disc rotor using a micrometer. Replace the disc rotor if the thickness is below the wear limit.

#### Limit

#### Wear limit thickness

: Refer to [BR-64, "Rear Disc Brake"](#).

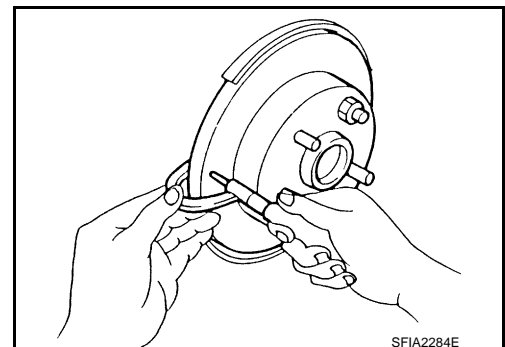

# BRAKE PEDAL

< REMOVAL AND INSTALLATION >

## REMOVAL AND INSTALLATION

### BRAKE PEDAL

#### Exploded View

INFOID:000000001832370

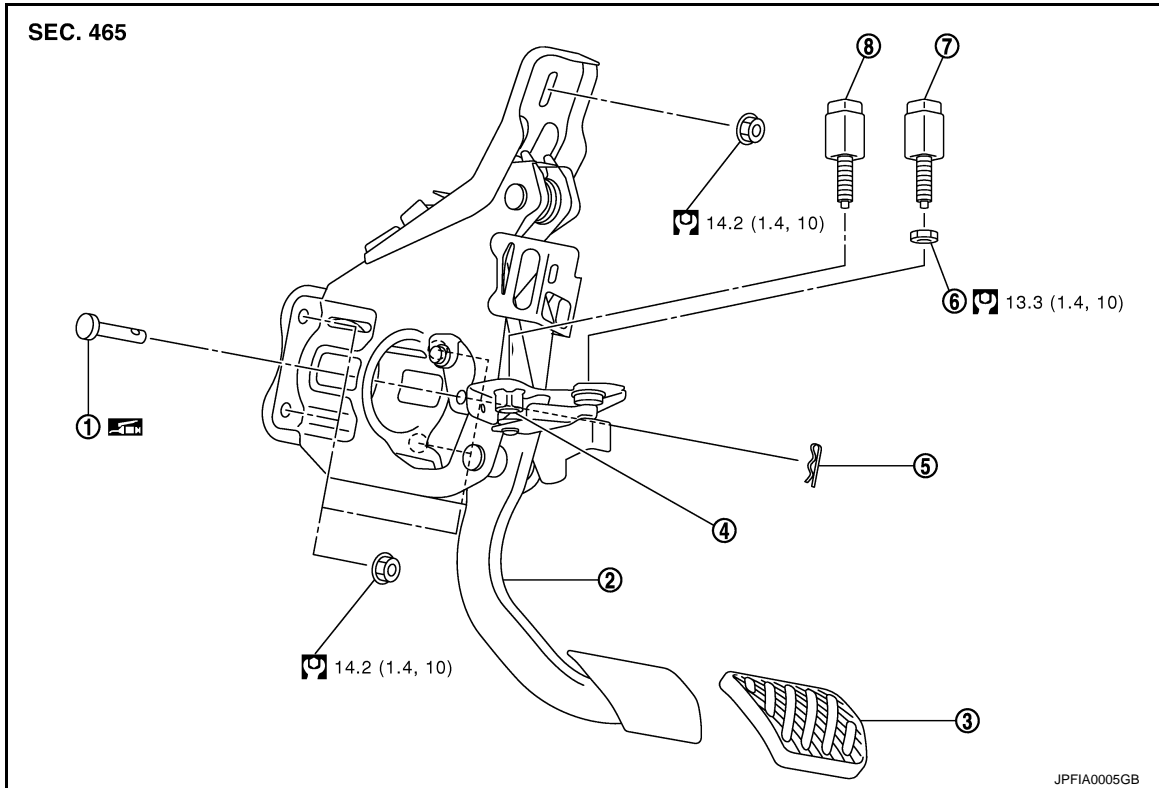

- |                      |                         |                    |
|----------------------|-------------------------|--------------------|
| 1. Clevis pin        | 2. Brake pedal assembly | 3. Brake pedal pad |
| 4. Clip              | 5. Snap pin             | 6. Lock nut        |
| 7. ASCD brake switch | 8. Stop lamp switch     |                    |

: Apply multi-purpose grease.

Refer to [GI-4, "Components"](#) for symbols not described on the above.

### Removal and Installation

INFOID:000000001832371

#### REMOVAL

1. Remove instrument driver lower panel. Refer to [IP-11, "Exploded View"](#).
2. Remove steering column assembly. Refer to [ST-18, "WITHOUT ELECTRIC MOTOR : Exploded View"](#) (without electric motor), [ST-19, "WITH ELECTRIC MOTOR : Exploded View"](#) (with electric motor).
3. Disconnect the stop lamp switch and ASCD brake switch harness connectors.
4. Turn the stop lamp switch counterclockwise to remove the stop lamp switch.
5. Loosen the lock nut for the ASCD brake switch and remove the ASCD brake switch.
6. Remove snap pin and clevis pin from clevis of brake booster.
7. Remove cowl top cover. Refer to [EXT-20, "Exploded View"](#).
8. Remove instrument panel assembly. Refer to [IP-11, "Exploded View"](#).
9. Slide the steering member rearward.
10. Remove brake pedal assembly.

#### INSTALLATION

Note the following, and installation in the reverse order of removal.

# BRAKE PEDAL

## < REMOVAL AND INSTALLATION >

- Apply the multi-purpose grease to the clevis pin and the mating faces. (Not necessary if grease has been already applied)

### NOTE:

The clevis pin may be inserted in either direction.

## Inspection and Adjustment

INFOID:000000001832372

### INSPECTION AFTER REMOVAL

- Check the following items and replace the brake pedal assembly if necessary.
  - Check the brake pedal upper rivet (made by aluminum) (A) for deformation.
  - Check the brake pedal for bend, damage, and cracks on the welded parts.
  - Check the lapping length (X) of sub-bracket (B) and slide plate (C).

#### Standard

**X : 5.0 mm (0.197 in) or more**

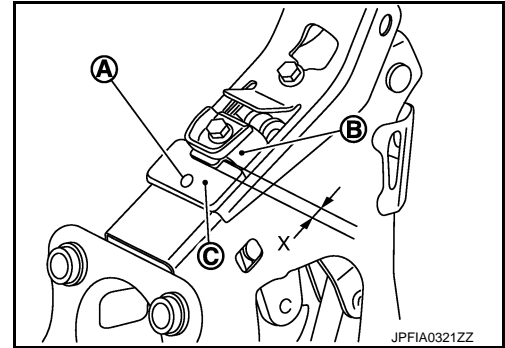

- Check clevis pin and plastic stopper (A) for damage and deformation. If any damage is found, replace clevis pin.

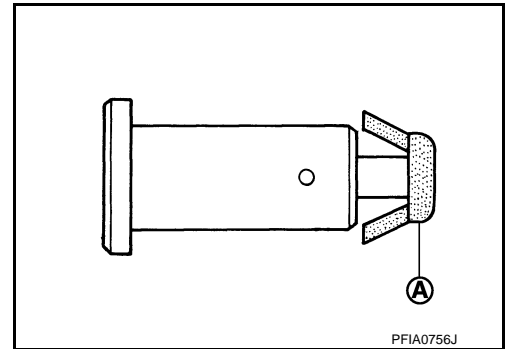

### ADJUSTMENT AFTER INSTALLATION

Perform the brake pedal adjustment after installing the brake pedal assembly. Refer to [BR-8. "Inspection and Adjustment"](#).

A  
B  
C  
D  
E  
BR  
G  
H  
I  
J  
K  
L  
M  
N  
O  
P

# BRAKE PIPING

< REMOVAL AND INSTALLATION >

## BRAKE PIPING

### FRONT

### FRONT : Exploded View

INFOID:000000001832373

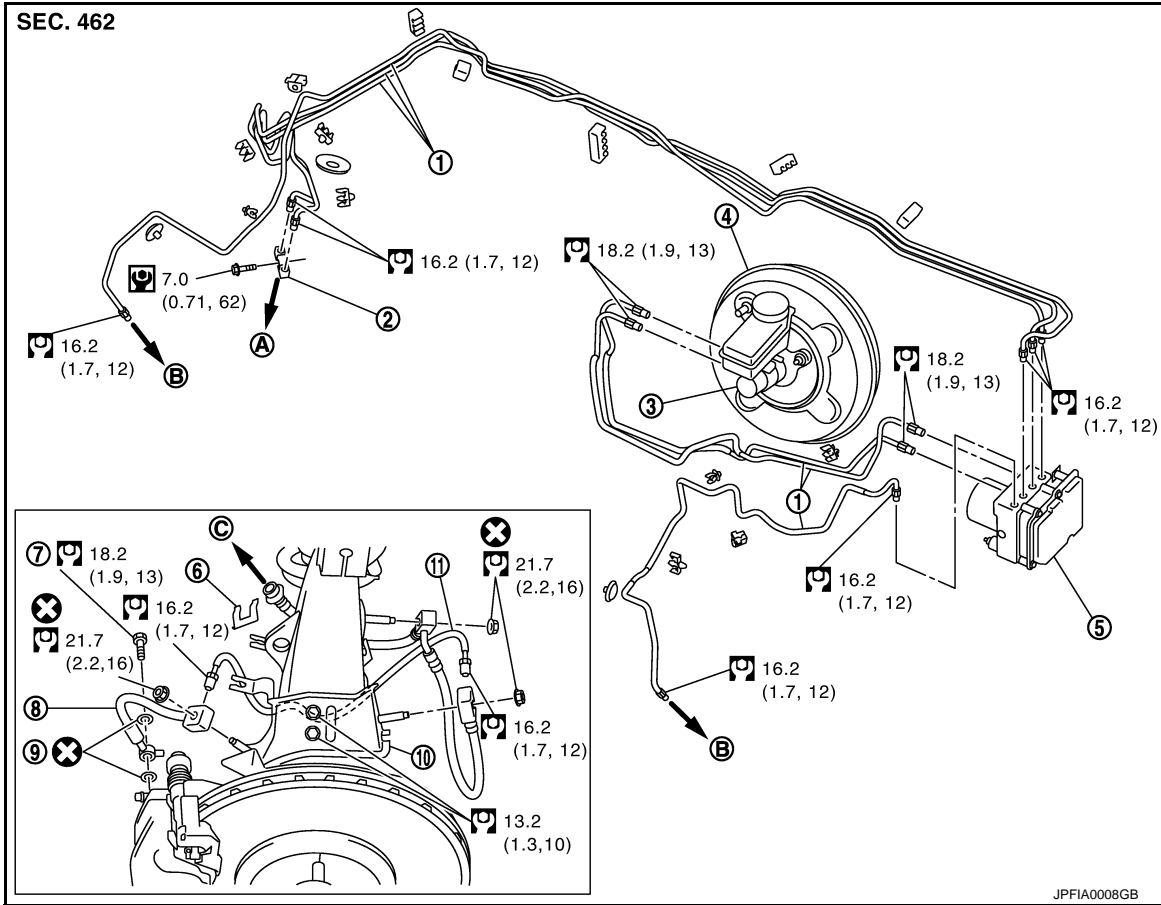

- |                        |  |                        |
|------------------------|--|------------------------|
| 1. Brake tube          | 2. Connector                                     | 3. Master cylinder     |
| 4. Brake booster       | 5. ABS actuator and electric unit (control unit) | 6. Lock plate          |
| 7. Union bolt          | 8. Brake hose                                    | 9. Copper washer       |
| 10. Brake hose bracket | 11. Brake tube                                   |                        |
| A. To rear brake tube  | B. To front brake hose                           | C. To front brake tube |

Refer to [GI-4, "Components"](#) for symbols in the figure.

# BRAKE PIPING

< REMOVAL AND INSTALLATION >

## FRONT : Hydraulic Piping

INFOID:000000001832374

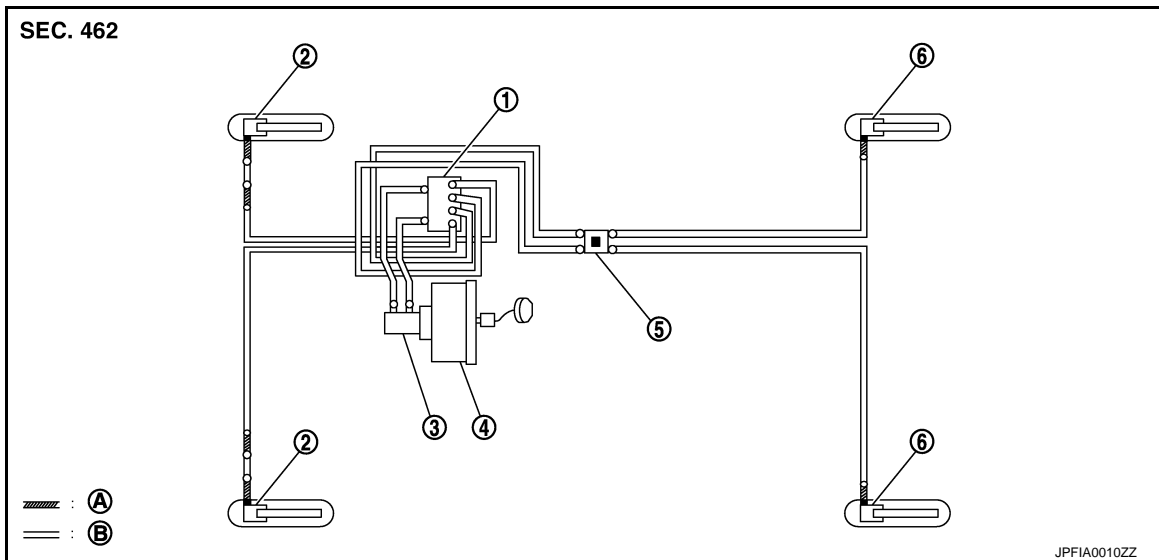

- |  |                     |                    |
|--|---------------------|--------------------|
| 1. ABS actuator and electric unit (control unit) | 2. Front disc brake | 3. Master cylinder |
| 4. Brake booster                                 | 5. Connector        | 6. Rear disc brake |
| A. Brake hose                                    | B. Brake tube       |                    |

- : Flare nut  
■ : Union bolt  
■ : Connector

## FRONT : Removal and Installation

INFOID:000000001832375

### REMOVAL

#### CAUTION:

Never spill or splash brake fluid on painted surfaces. Brake fluid may seriously damage paint. Wipe it off immediately and wash with water if it gets on a painted surface.

1. Remove tires with power tool.
2. Drain brake fluid. Refer to [BR-12. "Draining"](#).
3. Loosen the flare nut with a flare nut wrench and separate the brake tube from the hose.

#### CAUTION:

- Never scratch the flare nut and the brake tube.
- Never bend sharply, twist or strongly pull out the brake hoses and tubes.
- Cover open end of brake tubes and hoses when disconnecting to prevent entrance of dirt.

4. Remove the union bolt and remove the brake hose from the brake caliper assembly.
5. Remove the brake hose mounting nut.
6. Remove the lock plate and remove the brake hose.

### INSTALLATION

#### CAUTION:

Never spill or splash brake fluid on painted surfaces. Brake fluid may seriously damage paint. Wipe it off immediately and wash with water if it gets on a painted surface.

1. Assemble the union bolt and the copper washer to the brake hose.

#### CAUTION:

Never reuse the copper washer.

# BRAKE PIPING

## < REMOVAL AND INSTALLATION >

2. Align the brake hose pin to the projection (A) of the brake caliper assembly and tighten the union bolt (1) to the specified torque.
3. Install the brake tube to the brake hose, temporarily tighten the flare nut by hand until it does not rotate further, and fix the brake hose to the bracket with the lock plate.

**CAUTION:**

**Check that all brake hoses and tubes are not twisted and bent.**

4. Tighten the flare nut to the specified torque with a flare nut crow-foot and a torque wrench.

**CAUTION:**

**Never scratch the flare nut and the brake tube.**

5. Tighten the brake hose mounting nuts to the specified torque.

**CAUTION:**

**Never reuse the brake hose mounting nuts.**

6. Refill with new brake fluid and perform the air bleeding. Refer to [BR-13. "Bleeding Brake System"](#).

**CAUTION:**

**Never reuse drained brake fluid.**

7. Install tires.

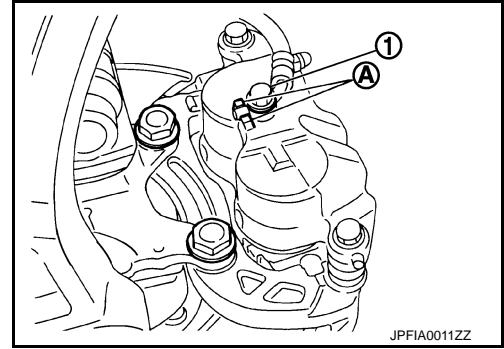

## FRONT : Inspection

INFOID:000000001832376

## INSPECTION AFTER INSTALLATION

1. Check the brake hoses and tubes for the following: no scratches; no twist and deformation; no interference with other components when steering the steering wheel; no looseness at connections.
2. Depress the brake pedal with a force of 785 N (80 kg, 176 lb) and hold down the pedal for approximately 5 seconds with the engine running. Check for any fluid leakage.

**CAUTION:**

**Retighten the applicable connection to the specified torque and repair any abnormal (damaged, worn or deformed) part if any brake fluid leakage is present.**

## REAR

# BRAKE PIPING

< REMOVAL AND INSTALLATION >

REAR : Exploded View

INFOID:000000001832377

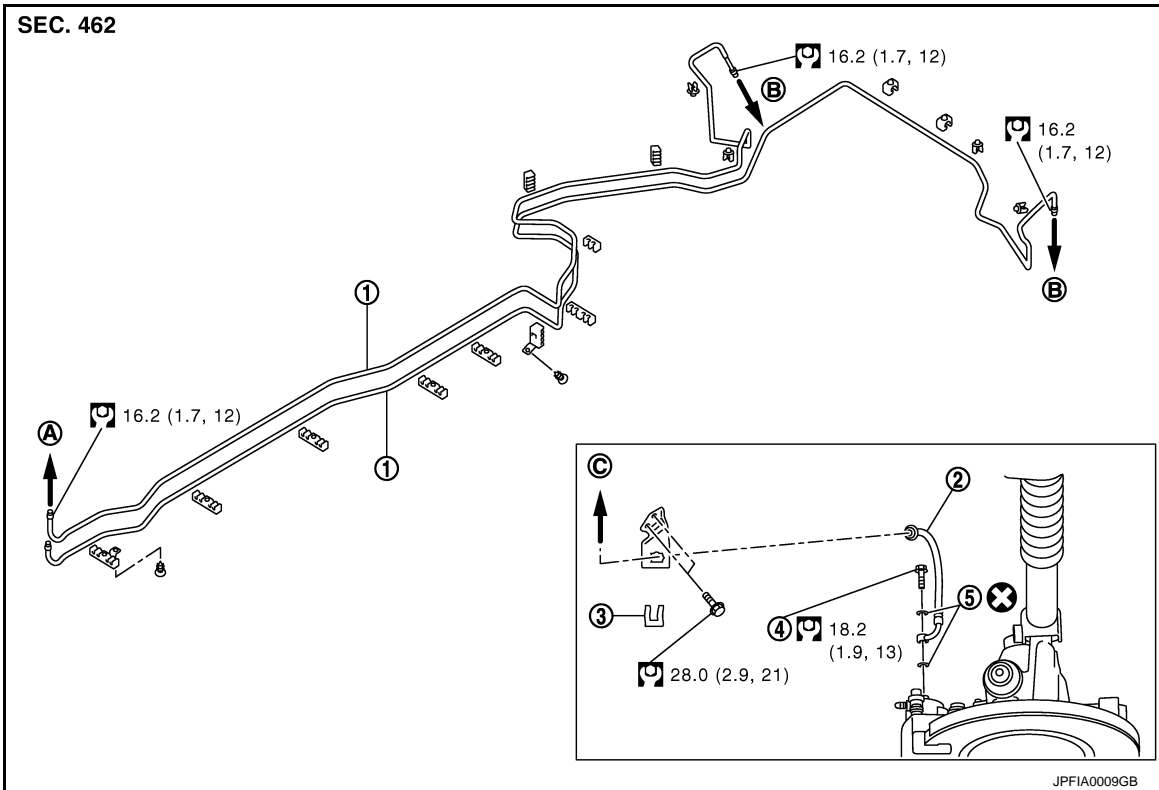

- |                        |                       |                       |
|------------------------|-----------------------|-----------------------|
| 1. Brake tube          | 2. Brake hose         | 3. Lock plate         |
| 4. Union bolt          | 5. Copper washer      |                       |
| A. To front brake tube | B. To rear brake hose | C. To rear brake tube |

Refer to [GI-4. "Components"](#) for symbols in the figure.

REAR : Hydraulic Piping

INFOID:000000001832378

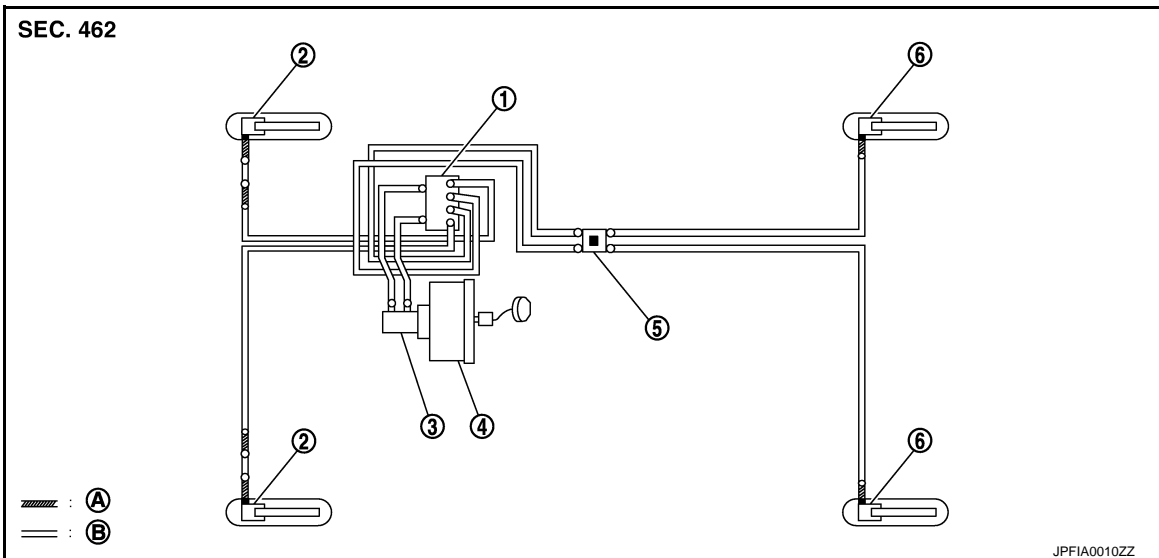

- |  |                     |                    |
|--|---------------------|--------------------|
| 1. ABS actuator and electric unit (control unit) | 2. Front disc brake | 3. Master cylinder |
| 4. Brake booster                                 | 5. Connector        | 6. Rear disc brake |

# BRAKE PIPING

## < REMOVAL AND INSTALLATION >

A. Brake hose

B. Brake tube

○: Flare nut

■: Union bolt

▣: Connector

### REAR : Removal and Installation

INFOID:000000001832379

#### REMOVAL

##### CAUTION:

Never spill or splash brake fluid on painted surfaces. Brake fluid may seriously damage paint. Wipe it off immediately and wash with water if it gets on a painted surface.

1. Remove tires with power tool.
2. Drain brake fluid. Refer to [BR-12. "Draining"](#).
3. Loosen the flare nut with a flare nut wrench and separate the brake tube from the hose.

##### CAUTION:

- Never scratch the flare nut and the brake tube.
- Never sharply bend, twist or strongly pull the brake hoses and tubes.
- Cover the open end of brake tubes and hoses when disconnecting to prevent entrance of dirt.

4. Remove the union bolt and remove the brake hose from the brake caliper assembly.
5. Remove the lock plate and remove the brake hose from the vehicle.

#### INSTALLATION

##### CAUTION:

Never spill or splash brake fluid on painted surfaces. Brake fluid may seriously damage paint. Wipe it off immediately and wash with water if it gets on a painted surface.

1. Assemble the union bolt and the copper washer to the brake hose.

##### CAUTION:

Never reuse copper washer.

2. Install the brake hose L-pin by aligning it with the brake caliper assembly positioning hole, and tighten the union bolt (1) to the specified torque.
3. Connect the hose to the brake tube, temporarily tighten the flare nut by hand until it does not rotate further, and fix the brake hose to the bracket with the lock plate.

##### CAUTION:

Check that the brake hoses and tubes are not twisted and bent.

4. Tighten the flare nut to the specified torque with a flare nut crow-foot and torque wrench.

##### CAUTION:

Never scratch the flare nut and the brake tube.

5. Refill with new brake fluid and perform the air bleeding. Refer to [BR-13. "Bleeding Brake System"](#).

##### CAUTION:

Never reuse drained brake fluid.

6. Install tires.

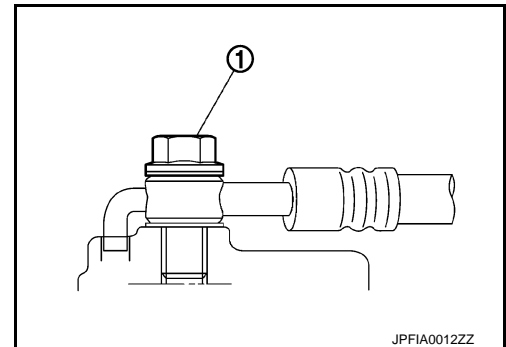

### REAR : Inspection

INFOID:000000001832380

#### INSPECTION AFTER REMOVAL

1. Check the brake hoses and tubes for the following: no scratches; no twist and deformation; no interference with other components when steering the steering wheel; no looseness at connections.
2. Depress the brake pedal with a force of 785 N (80kg, 176 lb) and hold down the pedal for approximately 5 seconds with the engine running. Check for any fluid leakage.

##### CAUTION:

Retighten the applicable connection to the specified torque and repair any abnormal (damaged, worn or deformed) part if any brake fluid leakage is present.



# BRAKE MASTER CYLINDER

< REMOVAL AND INSTALLATION >

## BRAKE MASTER CYLINDER

2WD

2WD : Exploded View

INFOID:000000001832381

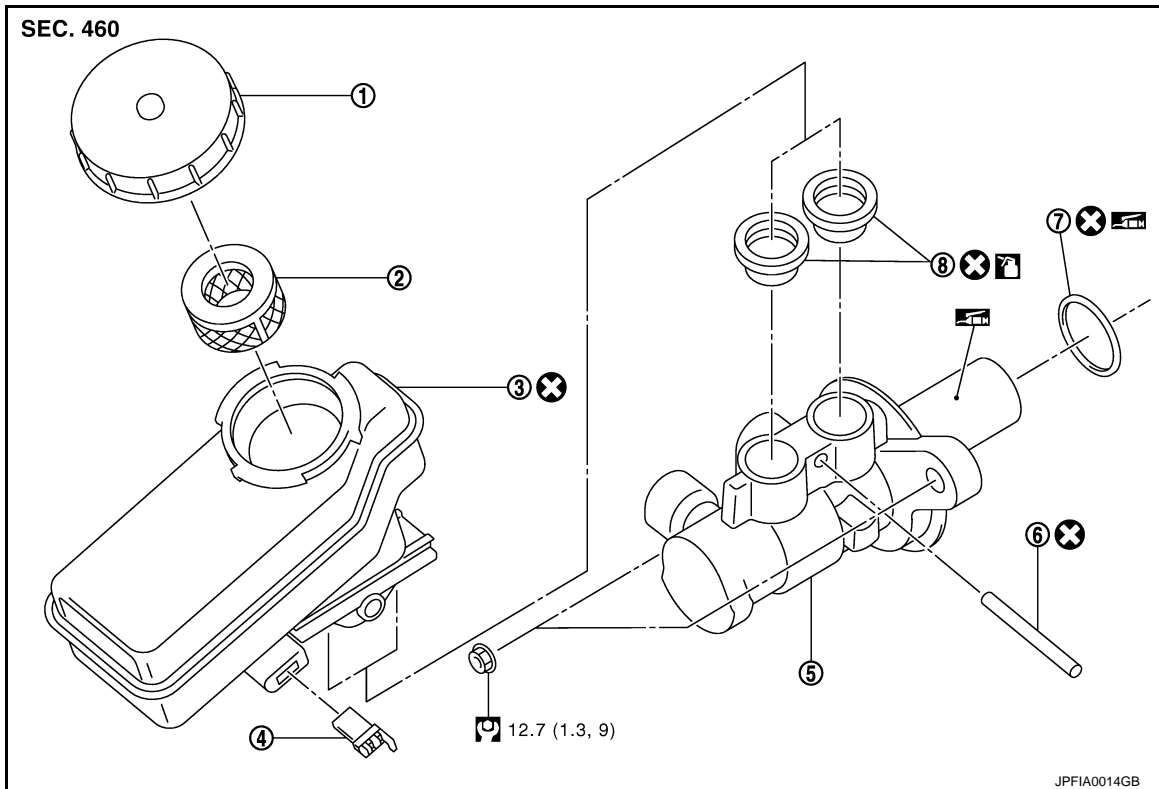

- |                                       |                  |                   |
|---------------------------------------|------------------|-------------------|
| 1. Reservoir cap                      | 2. Oil strainer  | 3. Reservoir tank |
| 4. Brake fluid level switch connector | 5. Cylinder body | 6. Pin            |
| 7. O-ring                             | 8. Grommet       |                   |

: Apply PBC (Poly Butyl Cuprysil) grease or silicone-based grease.

: Apply brake fluid.

Refer to [GI-4, "Components"](#) for symbols not described on the above.

## 2WD : Removal and Installation

INFOID:000000001832382

### REMOVAL

#### CAUTION:

**Never spill or splash brake fluid on painted surfaces. Brake fluid may seriously damage paint. Wipe it off immediately and wash with water if it gets on a painted surface.**

1. Remove the master cylinder cover.
2. Drain brake fluid. Refer to [BR-12, "Draining"](#).
3. Separate the brake fluid level switch harness connector.
4. Separate the brake tube from the master cylinder assembly with a flare nut wrench.

#### CAUTION:

**Never scratch the flare nut and the brake tube.**

5. Remove the master cylinder assembly.

#### CAUTION:

- **Depress the brake pedal several times to release the vacuum pressure from the brake booster. Then remove the master cylinder assembly.**
- **Never depress the brake pedal after the master cylinder assembly is removed.**

# BRAKE MASTER CYLINDER

## < REMOVAL AND INSTALLATION >

- The piston of the master cylinder assembly is exposed. Never damage it when removing the master cylinder.
- The piston may drop off when pulled out strongly. Never hold the piston. Hold the cylinder body when handling the master cylinder assembly.

## INSTALLATION

### CAUTION:

Never spill or splash brake fluid on painted surfaces. Brake fluid may seriously damage paint. Wipe it off immediately and wash with water if it gets on a painted surface.

Note the following, and installation in the reverse order of removal.

### CAUTION:

- Never depress the brake pedal after the master cylinder assembly is removed.
- Apply PBC (Poly Butyl Cuprysil) silicone-based grease to the brake booster [see (A) in the figure] when installing the master cylinder assembly to the brake booster.
- The piston of the master cylinder assembly is exposed. Never damage it when handling the master cylinder and check that no dirt and dust are present on the piston before installation. Clean it with new brake fluid if necessary.
- The piston may drop off when pulled strongly. Never hold the piston. Hold the cylinder body when handling the master cylinder assembly.
- Never reuse the O ring.
- Temporarily tighten the brake tube flare nut to the master cylinder assembly by hand. Then tighten it to the specified torque with a flare nut crowfoot and torque wrench. Refer to [BR-20, "FRONT : Exploded View"](#).

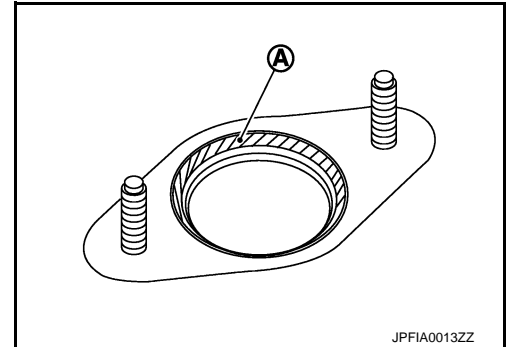

### CAUTION:

Never scratch the flare nut and the brake tube.

- After installation, perform the air bleeding. Refer to [BR-13, "Bleeding Brake System"](#)

### CAUTION:

Never reuse drained brake fluid.

## 2WD : Disassembly and Assembly

INFOID:000000001832383

## DISASSEMBLY

### CAUTION:

- Never disassemble the cylinder body.
- Remove the reservoir tank only when necessary.

1. Fix the master cylinder assembly to a vise.

### CAUTION:

Always set copper plates or cloth between them when fixing the cylinder body to a vise. Never overtighten the vise.

2. Remove the reservoir tank mounting pin with a pin punch.
3. Remove the reservoir tank and grommet from the cylinder body.

### CAUTION:

Never drop the removed parts. The parts must not be reused if they are dropped.

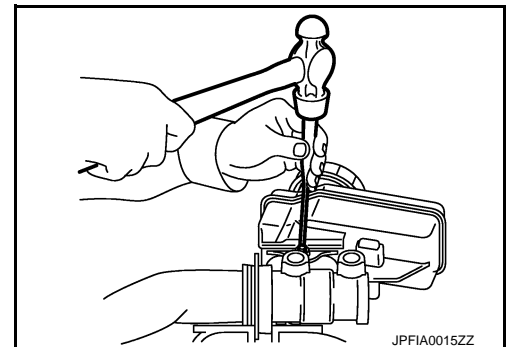

## ASSEMBLY

1. Apply new brake fluid to the grommet and install it to the cylinder body.

### CAUTION:

- Never use mineral oil such as gasoline or light oil.
- Never reuse the grommets.

2. Install the reservoir tank to the cylinder body.

# BRAKE MASTER CYLINDER

## < REMOVAL AND INSTALLATION >

### CAUTION:

Never drop the parts when installing. The parts must not be reused if they are dropped.

3. Fix the cylinder body to a vise.

### CAUTION:

- Place the reservoir tank with the chamfered pin hole (←) facing up.
- Always set copper plates or cloth between them when fixing the cylinder body to a vise. Never overtighten the vise.

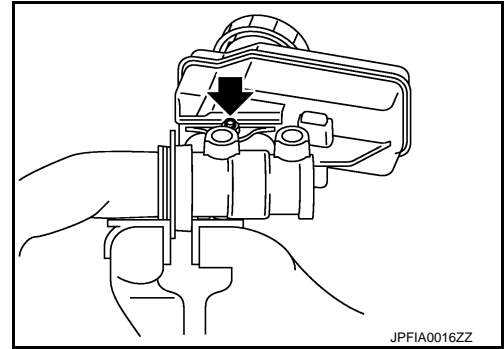

4. Tilt the reservoir tank so that a mounting pin can be inserted. Insert a mounting pin. Return the reservoir tank to the horizontal position. Insert another mounting pin into the pin hole on the opposite side in the same manner after the mounting pin passes through the cylinder body pin hole.

### CAUTION:

Never reuse the mounting pins.

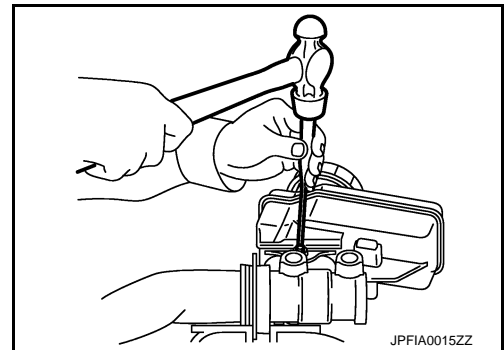

INFOID:000000001832384

2WD : Inspection

## INSPECTION AFTER INSTALLATION

### Fluid Leak

Check for brake fluid leakage from the cylinder body-to-brake booster mounting face, reservoir tank mounting face and brake tube connections.

AWD

A  
B  
C  
D  
E  
BR  
G  
H  
I  
J  
K  
L  
M  
N  
O  
P

# BRAKE MASTER CYLINDER

< REMOVAL AND INSTALLATION >

AWD : Exploded View

INFOID:000000001832385

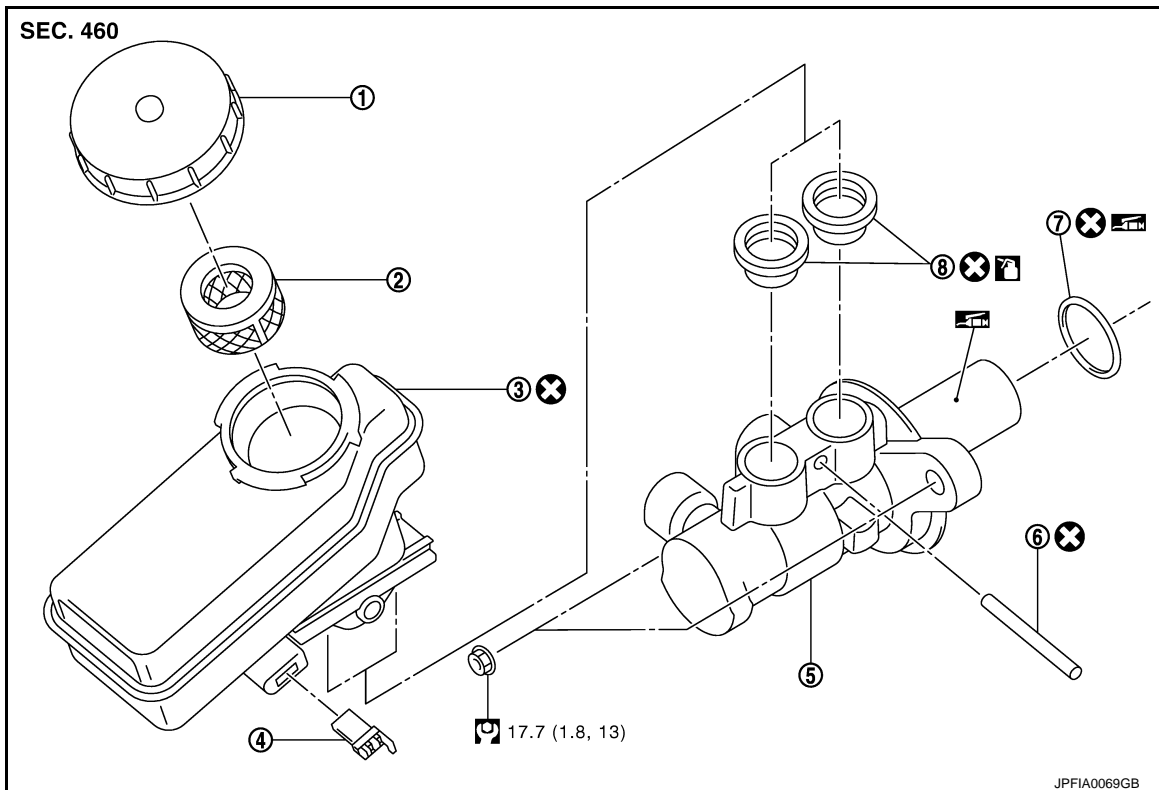

- |                                       |                  |                   |
|---------------------------------------|------------------|-------------------|
| 1. Reservoir cap                      | 2. Oil strainer  | 3. Reservoir tank |
| 4. Brake fluid level switch connector | 5. Cylinder body | 6. Pin            |
| 7. O-ring                             | 8. Grommet       |                   |

Apply PBC (Poly Butyl Cuprysil) grease or silicone-based grease.

Apply brake fluid.

Refer to [GI-4, "Components"](#) for symbols not described on the above.

AWD : Removal and Installation

INFOID:000000001832386

## REMOVAL

### CAUTION:

**Never spill or splash brake fluid on painted surfaces. Brake fluid may seriously damage paint. Wipe it off immediately and wash with water if it gets on a painted surface.**

1. Remove the master cylinder cover.
2. Drain brake fluid. Refer to [BR-12, "Draining"](#).
3. Separate the brake fluid level switch harness connector.
4. Separate the brake tube from the master cylinder assembly with a flare nut wrench.

### CAUTION:

**Never scratch the flare nut and the brake tube.**

5. Remove the master cylinder assembly.

### CAUTION:

- Depress the brake pedal several times to release the vacuum pressure from the brake booster. Then remove the master cylinder assembly.
- Never depress the brake pedal after the master cylinder assembly is removed.
- The piston of the master cylinder assembly is exposed. Never damage it when removing the master cylinder.
- The piston may drop off when pulled out strongly. Never hold the piston. Hold the cylinder body when handling the master cylinder assembly.

# BRAKE MASTER CYLINDER

## < REMOVAL AND INSTALLATION >

### INSTALLATION

#### CAUTION:

Never spill or splash brake fluid on painted surfaces. Brake fluid may seriously damage paint. Wipe it off immediately and wash with water if it gets on a painted surface.

Note the following, and installation in the reverse order of removal.

#### CAUTION:

- Never depress the brake pedal after the master cylinder assembly is removed.
- Apply PBC (Poly Butyl Cuprysil) silicone-based grease to the brake booster [see (A) in the figure] when installing the master cylinder assembly to the brake booster.
- The piston of the master cylinder assembly is exposed. Never damage it when handling the master cylinder and check that no dirt and dust are present on the piston before installation. Clean it with new brake fluid if necessary.
- The piston may drop off when pulled strongly. Never hold the piston. Hold the cylinder body when handling the master cylinder assembly.
- Never reuse the O ring.
- Temporarily tighten the brake tube flare nut to the master cylinder assembly by hand. Then tighten it to the specified torque with a flare nut crowfoot and torque wrench. Refer to [BR-20, "FRONT : Exploded View"](#).

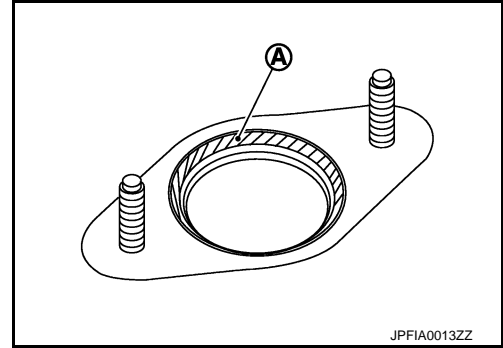

A  
B  
C  
D  
E  
BR

#### CAUTION:

Never scratch the flare nut and the brake tube.

- After installation, perform the air bleeding. Refer to [BR-13, "Bleeding Brake System"](#)

#### CAUTION:

Never reuse drained brake fluid.

### AWD : Disassembly and Assembly

INFOID:000000001832387

### DISASSEMBLY

#### CAUTION:

- Never disassemble the cylinder body.
  - Remove the reservoir tank only when necessary.
1. Fix the master cylinder assembly to a vise.  
**CAUTION:**  
Always set copper plates or cloth between them when fixing the cylinder body to a vise. Never overtighten the vise.
  2. Remove the reservoir tank mounting pin with a pin punch.
  3. Remove the reservoir tank and grommet from the cylinder body.  
**CAUTION:**  
Never drop the removed parts. The parts must not be reused if they are dropped.

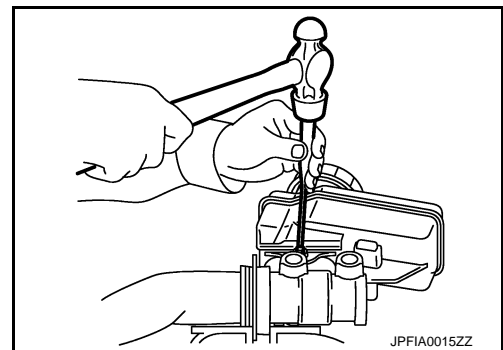

G  
H  
I  
J  
K  
L  
M  
N  
O

### ASSEMBLY

1. Apply new brake fluid to the grommet and install it to the cylinder body.  
**CAUTION:**
  - Never use mineral oil such as gasoline or light oil.
  - Never reuse the grommets.
2. Install the reservoir tank to the cylinder body.  
**CAUTION:**  
Never drop the parts when installing. The parts must not be reused if they are dropped.

P

# BRAKE MASTER CYLINDER

## < REMOVAL AND INSTALLATION >

3. Fix the cylinder body to a vise.

**CAUTION:**

- Place the reservoir tank with the chamfered pin hole (←) facing up.
- Always set copper plates or cloth between them when fixing the cylinder body to a vise. Never overtighten the vise.

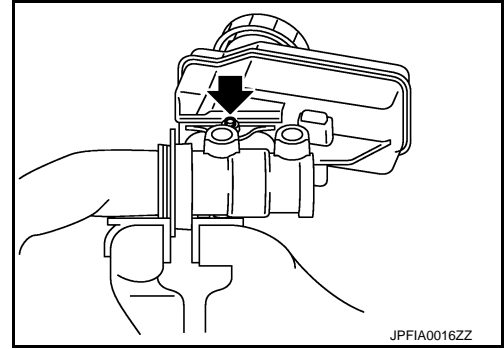

4. Tilt the reservoir tank so that a mounting pin can be inserted. Insert a mounting pin. Return the reservoir tank to the horizontal position. Insert another mounting pin into the pin hole on the opposite side in the same manner after the mounting pin passes through the cylinder body pin hole.

**CAUTION:**

**Never reuse the mounting pins.**

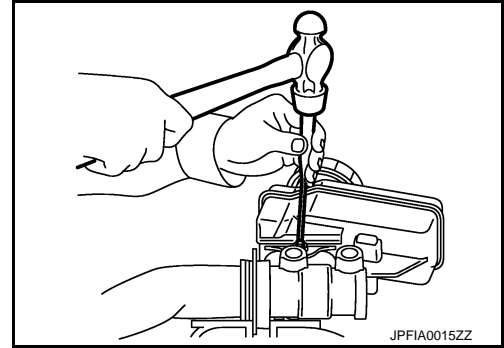

AWD : Inspection

INFOID:000000001832388

## INSPECTION AFTER INSTALLATION

### Fluid Leak

Check for brake fluid leakage from the cylinder body-to-brake booster mounting face, reservoir tank mounting face and brake tube connections.

# BRAKE BOOSTER

< REMOVAL AND INSTALLATION >

## BRAKE BOOSTER

2WD

2WD : Exploded View

INFOID:000000001832389

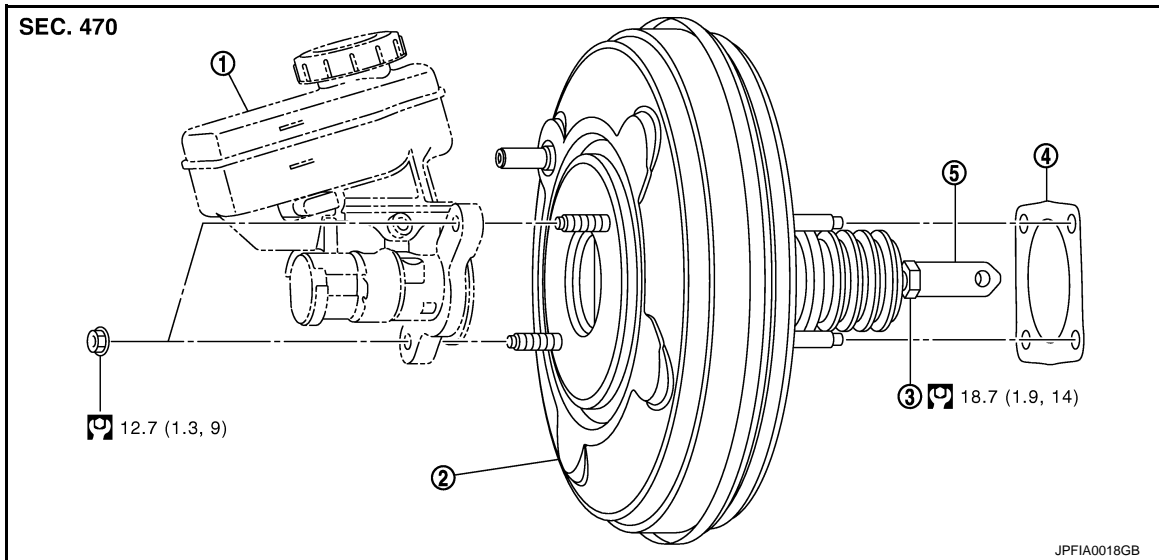

1. Master cylinder assembly
2. Brake booster
3. Lock nut
4. Gasket
5. Clevis

Refer to [GI-4, "Components"](#) for symbols in the figure.

2WD : Removal and installation

INFOID:000000001832390

### REMOVAL

1. Remove master cylinder cover.
2. Remove cowl top cover. Refer to [EXT-20, "Exploded View"](#).
3. Remove brake master cylinder assembly. Refer to [BR-25, "2WD : Exploded View"](#).

#### CAUTION:

- Depress the brake pedal several times to release the vacuum pressure from the brake booster. Then remove the master cylinder assembly.
- Never depress the brake pedal after the master cylinder assembly is removed.
- The piston of the master cylinder assembly is exposed. Never damage it when removing the master cylinder.
- The piston may drop off when pulled out strongly. Never hold the piston. Hold the cylinder body when handling the master cylinder assembly.

4. Remove vacuum hose from brake booster. Refer to [BR-36, "Exploded View"](#).

5. Remove snap pin (1) and clevis pin (2) from inside vehicle.
6. Remove nuts on brake booster and brake pedal assembly. Refer to [BR-18, "Exploded View"](#).

7. Remove brake booster from dash panel in engine room side.

#### CAUTION:

Never deform or bend the brake tubes.

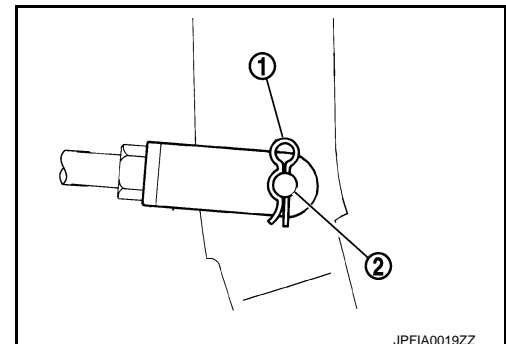

### INSTALLATION

Note the following, and installation in the reverse order of removal.

# BRAKE BOOSTER

## < REMOVAL AND INSTALLATION >

### CAUTION:

- Be careful not to damage brake booster stud bolt threads. If brake booster is tilted during installation, the dash panel may damage the threads.
- Never deform or bend the brake tubes when installing the brake booster.
- Always use a new gasket between the brake booster and the dash panel.
- Replace the clevis pin if it is damaged. Refer to [BR-19, "Inspection and Adjustment"](#).
- Install the brake pedal assembly and brake booster mounting nuts, and tighten it to the specified torque.
- After installation, perform the air bleeding. Refer to [BR-13, "Bleeding Brake System"](#).

### CAUTION:

Never reuse drained brake fluid.

## 2WD : Inspection and Adjustment

INFOID:000000001832391

### INSPECTION BEFORE REMOVAL

Air Tight

### CAUTION:

Check the air tight condition when the master cylinder and the brake booster is installed.

1. With a handy vacuum pump, apply vacuum pressure of  $-66.7$  kPa ( $-500$  mmHg,  $-19.70$  inHg) to the brake booster.
2. If the air tight condition cannot be maintained, perform the following operation.
  - a. Check the no dirt and dust are present on the brake booster and brake master cylinder mating faces. Clean it if necessary.
  - b. Check O-ring on the master cylinder. If anything is found, replace the O-ring.
  - c. Check the air tight condition again. If the condition still cannot be maintained, replace the brake booster.

### INSPECTION AFTER REMOVAL

Input Rod Length Inspection

1. Loosen the lock nut (1) and adjust the input rod (2) to the specified length (B).

Standard

Input rod length (B)

: Refer to [BR-63, "Brake Booster"](#)

2. Tighten the lock nut to the specified torque.

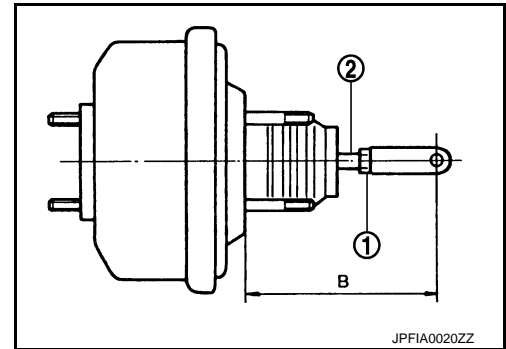

### INSPECTION AFTER INSTALLATION

Operation

Depress the brake pedal several times at 5-second intervals with the engine stopped. Start the engine with the brake pedal fully depressed. Check that the clearance between brake pedal and dash lower pane decreases.

### NOTE:

A slight impact with a small click may be felt on the pedal when the brake pedal is fully depressed. This is a normal phenomenon due to the brake system operation.

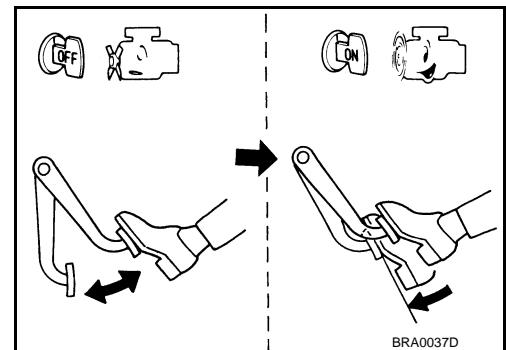

Air Tight



# BRAKE BOOSTER

## < REMOVAL AND INSTALLATION >

- Run the engine at idle for 1 minute to apply vacuum to the brake booster, and stop the engine. Then depress the brake pedal several times at 5-second intervals until the accumulated vacuum is released to atmospheric pressure. Check that the clearance between brake pedal and dash lower panel gradually increases (A → B → C) each time the brake pedal is depressed when performing this operation.

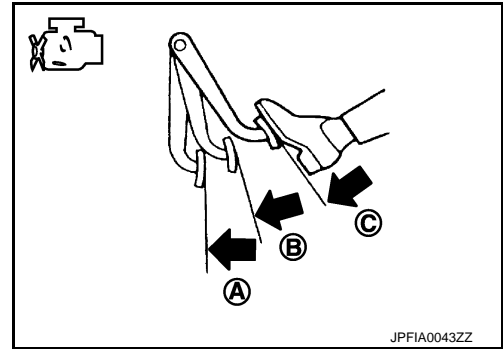

- Depress the brake pedal with the engine running. Then stop the engine while holding down the brake pedal. Check that the brake pedal stroke does not change after holding down the brake pedal for 30 seconds or more.

**NOTE:**

A slight impact with a small click may be felt on the pedal when the brake pedal is fully depressed. This is a normal phenomenon due to the brake system operation.

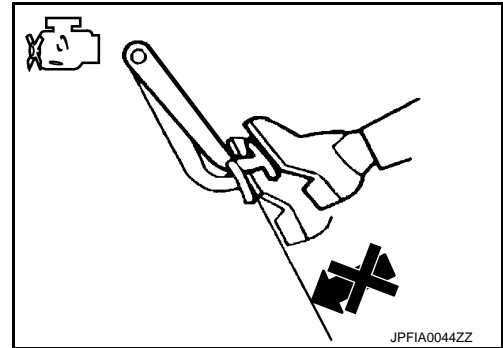

## ADJUSTMENT AFTER INSTALLTION

Perform the brake pedal adjustment after installing the brake pedal assembly. Refer to [BR-8, "Inspection and Adjustment"](#).

## AWD

### AWD : Exploded View

INFOID:000000001832392

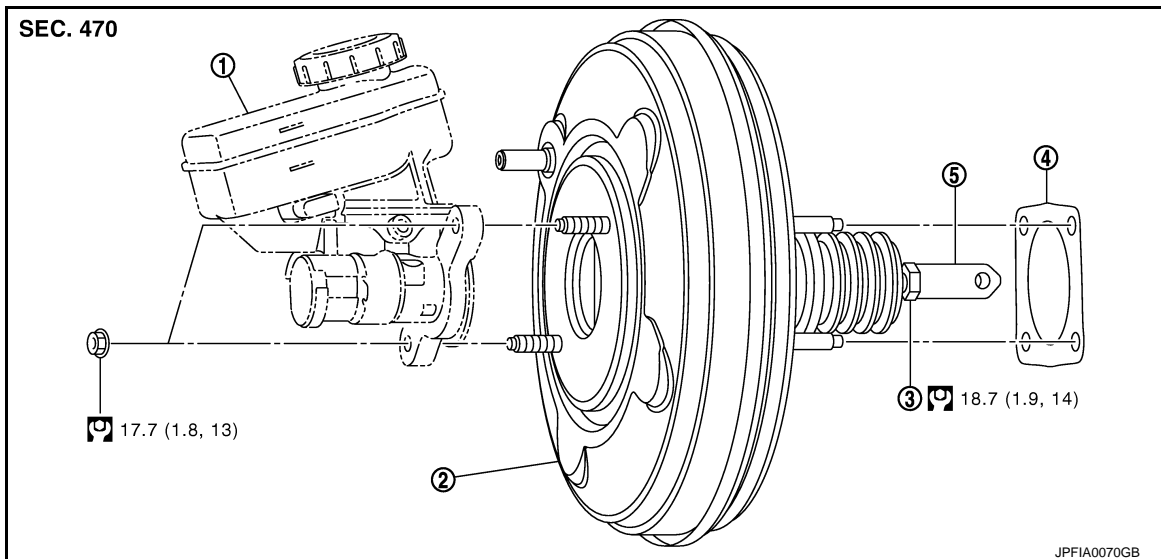

- |                             |                  |             |
|-----------------------------|------------------|-------------|
| 1. Master cylinder assembly | 2. Brake booster | 3. Lock nut |
| 4. Gasket                   | 5. Clevis        |             |

Refer to [GI-4, "Components"](#) for symbols in the figure.

## AWD : Removal and installation

INFOID:000000001832393

### REMOVAL

- Remove master cylinder cover.

# BRAKE BOOSTER

## < REMOVAL AND INSTALLATION >

2. Remove cowl top cover. Refer to [EXT-20, "Exploded View"](#).
3. Remove brake master cylinder assembly. Refer to [BR-28, "AWD : Exploded View"](#).

**CAUTION:**

- Depress the brake pedal several times to release the vacuum pressure from the brake booster. Then remove the master cylinder assembly.
- Never depress the brake pedal after the master cylinder assembly is removed.
- The piston of the master cylinder assembly is exposed. Never damage it when removing the master cylinder.
- The piston may drop off when pulled out strongly. Never hold the piston. Hold the cylinder body when handling the master cylinder assembly.

4. Remove vacuum hose from brake booster. Refer to [BR-36, "Exploded View"](#).
5. Remove snap pin (1) and clevis pin (2) from inside vehicle.
6. Remove nuts on brake booster and brake pedal assembly. Refer to [BR-18, "Exploded View"](#).
7. Remove brake booster from dash panel in engine room side.

**CAUTION:**

Never deform or bend the brake tubes.

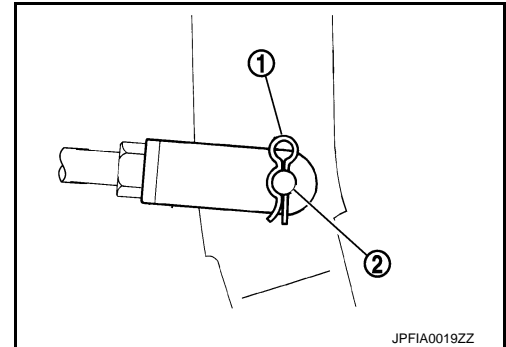

## INSTALLATION

Note the following, and installation in the reverse order of removal.

**CAUTION:**

- Be careful not to damage brake booster stud bolt threads. If brake booster is tilted during installation, the dash panel may damage the threads.
- Never deform or bend the brake tubes when installing the brake booster.
- Always use a new gasket between the brake booster and the dash panel.
- Replace the clevis pin if it is damaged. Refer to [BR-19, "Inspection and Adjustment"](#).
- Install the brake pedal assembly and brake booster mounting nuts, and tighten it to the specified torque.
- After installation, perform the air bleeding. Refer to [BR-13, "Bleeding Brake System"](#).

**CAUTION:**

Never reuse drained brake fluid.

## AWD : Inspection and Adjustment

INFOID:000000001832394

## INSPECTION BEFORE REMOVAL

Air Tight

**CAUTION:**

Check the air tight condition when the master cylinder and the brake booster is installed.

1. With a handy vacuum pump, apply vacuum pressure of  $-66.7$  kPa ( $-500$  mmHg,  $-19.70$  inHg) to the brake booster.
2. If the air tight condition cannot be maintained, perform the following operation.
  - a. Check the no dirt and dust are present on the brake booster and brake master cylinder mating faces. Clean it if necessary.
  - b. Check O-ring on the master cylinder. If anything is found, replace the O-ring.
  - c. Check the air tight condition again. If the condition still cannot be maintained, replace the brake booster.

## INSPECTION AFTER REMOVAL

Input Rod Length Inspection

# BRAKE BOOSTER

## < REMOVAL AND INSTALLATION >

1. Loosen the lock nut (1) and adjust the input rod (2) to the specified length (B).

**Standard**

**Input rod length (B)**

: Refer to [BR-63, "Brake Booster"](#)

2. Tighten the lock nut to the specified torque.

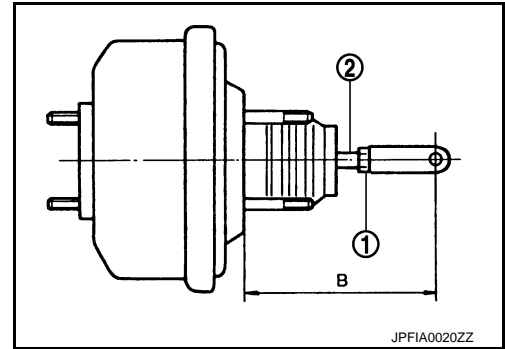

## INSPECTION AFTER INSTALLATION

### Operation

Depress the brake pedal several times at 5-second intervals with the engine stopped. Start the engine with the brake pedal fully depressed. Check that the clearance between brake pedal and dash lower pane decreases.

### NOTE:

A slight impact with a small click may be felt on the pedal when the brake pedal is fully depressed. This is a normal phenomenon due to the brake system operation.

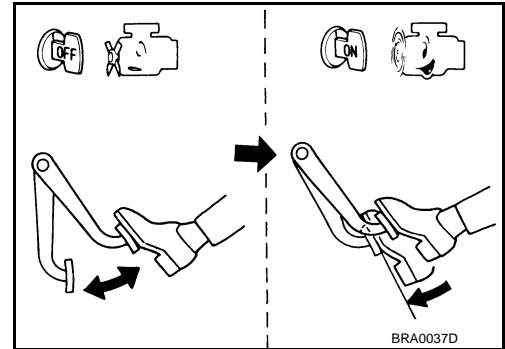

### Air Tight

- Run the engine at idle for 1 minute to apply vacuum to the brake booster, and stop the engine. Then depress the brake pedal several times at 5-second intervals until the accumulated vacuum is released to atmospheric pressure. Check that the clearance between brake pedal and dash lower panel gradually increases (A → B → C) each time the brake pedal is depressed when performing this operation.

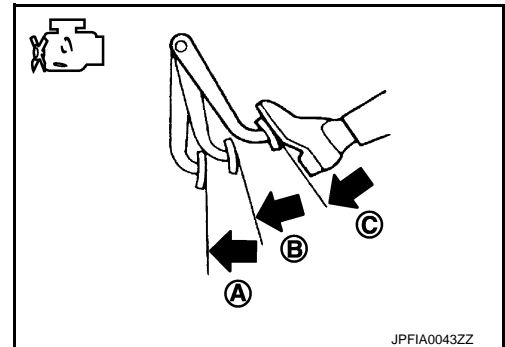

- Depress the brake pedal with the engine running. Then stop the engine while holding down the brake pedal. Check that the brake pedal stroke does not change after holding down the brake pedal for 30 seconds or more.

### NOTE:

A slight impact with a small click may be felt on the pedal when the brake pedal is fully depressed. This is a normal phenomenon due to the brake system operation.

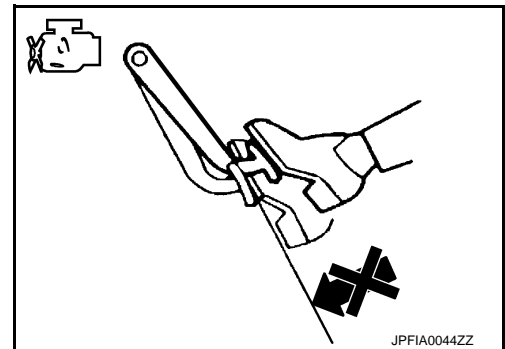

## ADJUSTMENT AFTER INSTALLTION

Perform the brake pedal adjustment after installing the brake pedal assembly. Refer to [BR-8, "Inspection and Adjustment"](#).

# VACUUM LINES

< REMOVAL AND INSTALLATION >

## VACUUM LINES

### Exploded View

INFOID:000000001832395

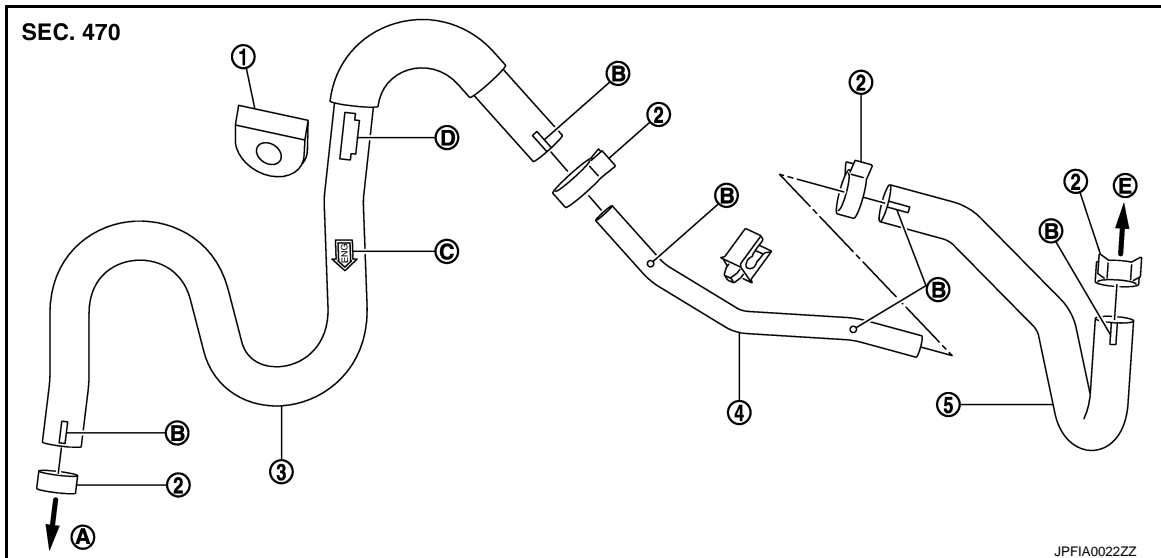

- |   |                     |                                       |
|---|---------------------|---------------------------------------|
| 1. Grommet  | 2. Clamp            | 3. Vacuum hose (built in check valve) |
| 4. Vacuum piping                                  | 5. Vacuum hose      |                                       |
| A. To intake manifold                             | B. Paint mark       | C. Stamp indicating engine direction  |
| D. Stamp indicating grommet installation position | E. To brake booster |                                       |

### Removal and Installation

INFOID:000000001832396

#### REMOVAL

1. Remove the engine cover. Refer to [EM-28, "Removal and Installation"](#).
2. Remove the cowl top cover. Refer to [EXT-20, "Exploded View"](#).
3. Remove the vacuum hose and tube.

#### INSTALLATION

Installation is the reverse order of removal.

#### CAUTION:

- Because vacuum hose contains a check valve, it must be installed in the correct position. Refer to the stamp to confirm correct installation. Brake booster will not operate normally if the hose is installed in the wrong direction.
- Insert vacuum hose at least 24 mm (0.94 in) (A).
- Never use lubricating oil during assembly.
- Face the marking side up when assembling.

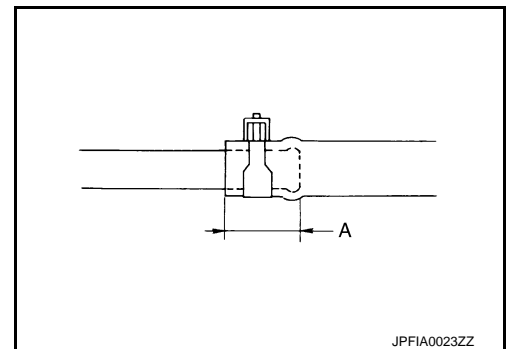

### Inspection

INFOID:000000001832397

#### INSPECTION AFTER REMOVAL

##### Appearance

Check for correct assembly, damage and deterioration.

##### Check Valve Airtightness

## VACUUM LINES

### < REMOVAL AND INSTALLATION >

- Use a handy vacuum pump (A) to check.

**When connected to the booster side (B):**

**Vacuum should decrease within 1.3 kPa (9.8 mm-Hg, 0.38 inHg) for 15 seconds under a vacuum of –66.7 kPa (–500 mmHg, –19.69 inHg).**

**When connected to the engine side (C):**

**Vacuum should not exist.**

- Replace vacuum hose assembly if vacuum hose and check valve are malfunctioning.

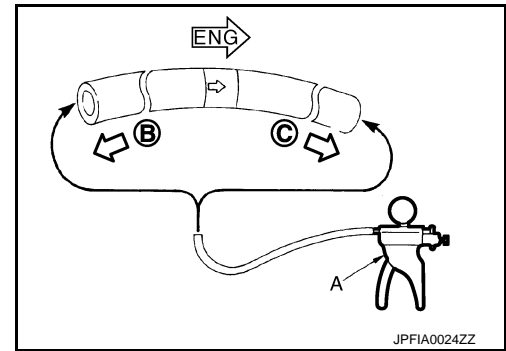

A  
B  
C  
D  
E  
BR  
G  
H  
I  
J  
K  
L  
M  
N  
O  
P

# FRONT DISC BRAKE

< REMOVAL AND INSTALLATION >

## FRONT DISC BRAKE BRAKE PAD (1 PISTON TYPE)

### BRAKE PAD (1 PISTON TYPE) : Exploded View

INFOID:000000001879589

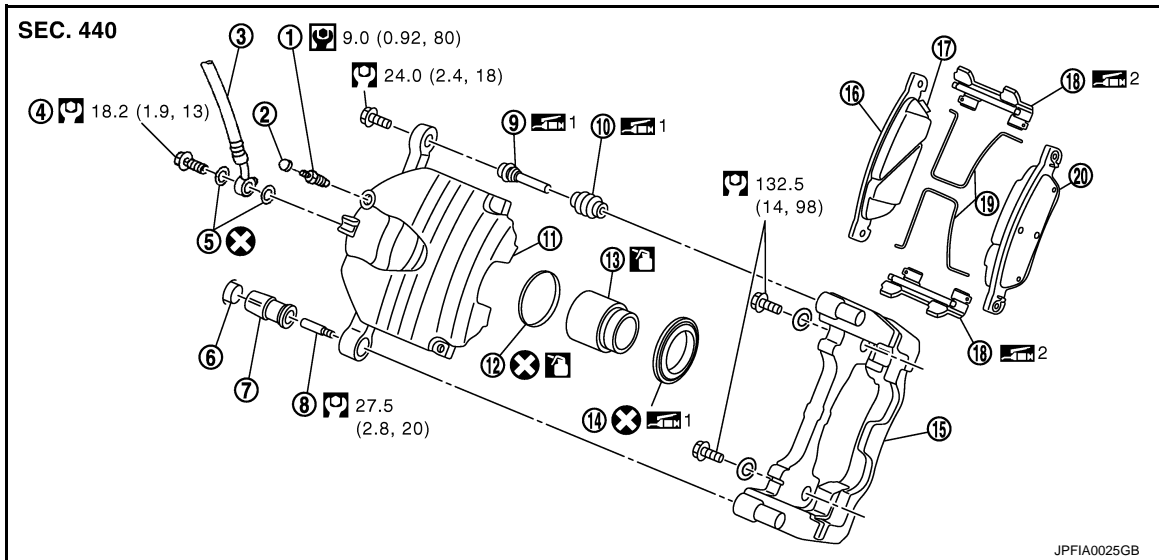

- |                       |                     |                   |
|-----------------------|---------------------|-------------------|
| 1. Bleeder valve      | 2. Cap              | 3. Brake hose     |
| 4. Union bolt         | 5. Copper washer    | 6. Protector      |
| 7. Bushing            | 8. Location pin     | 9. Sliding pin    |
| 10. Sliding pin boot  | 11. Cylinder body   | 12. Piston seal   |
| 13. Piston            | 14. Piston boot     | 15. Torque member |
| 16. Inner pad         | 17. Pad wear sensor | 18. Pad retainer  |
| 19. Pad return spring | 20. Outer pad       |                   |

1: Apply rubber grease.

2: Apply bentonite noise damping brake grease.

3: Apply brake fluid.

Refer to [GI-4, "Components"](#) for symbols not described on the above.

### BRAKE PAD (1 PISTON TYPE) : Removal and Installation

INFOID:000000001832399

#### REMOVAL

#### **WARNING:**

Clean any dust from the brake caliper and brake pads with a vacuum dust collector. Never blow with compressed air.

#### **CAUTION:**

- Never depress the brake pedal while removing the brake pads because the piston may pop out.
- Never spill or splash brake fluid on the disc rotor.

1. Remove tires with power tool.
2. Remove the protector and location pin.
3. Suspend the cylinder body with suitable wire so that the brake hose will not stretch. Remove the pad return spring and remove the brake pads from the torque member.

#### **CAUTION:**

- Never deform the pad return spring when removing the pad return spring.
- Never deform the pad retainers when removing the pad retainers from the torque member.
- Never damage the piston boot.
- Never remove the shims from the brake pads.
- Never drop the brake pads.

# FRONT DISC BRAKE

## < REMOVAL AND INSTALLATION >

### INSTALLATION

#### **WARNING:**

Clean any dust from the brake caliper and brake pads with a vacuum dust collector. Never blow with compressed air.

#### **CAUTION:**

- Never depress the brake pedal while removing the brake pads because the piston may pop out.
- Never spill or splash brake fluid on the disc rotor.

1. Apply bentonite noise damping brake grease to the pad retainers before it to installing the torque member if the pad retainers has been removed.

#### **CAUTION:**

- Securely assemble the pad retainers so that it will not be lifted up from the torque member.
- Never deform the pad retainers.

2. Install the brake pads to the torque member.

#### **CAUTION:**

The brake pads is directional. Never mistake the direction. (See the figure)

↶ : Direction of disc rotor rotation (Forward direction)

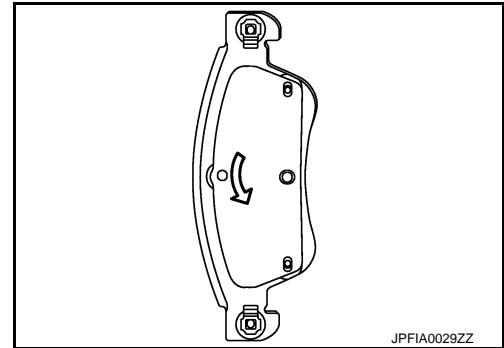

3. Install the pad return spring (1) to the brake pad (2).

#### **CAUTION:**

Correctly insert the pad return spring into the pad return spring hole on the brake pad.

4. Install cylinder body to torque member.

#### **CAUTION:**

- Never damage the piston boot.
- In the case of replacing a pad with new one, check a brake fluid level in the reservoir tank because brake fluid returns to master cylinder reservoir tank when pressing piston in.

#### **NOTE:**

Use a disc brake piston tool to easily press piston.

5. Install the location pin and tighten it to the specified torque.
6. Install the protector.
7. Depress the brake pedal several times to check that no drag feel is present for the front disc brake.
8. Install tires.

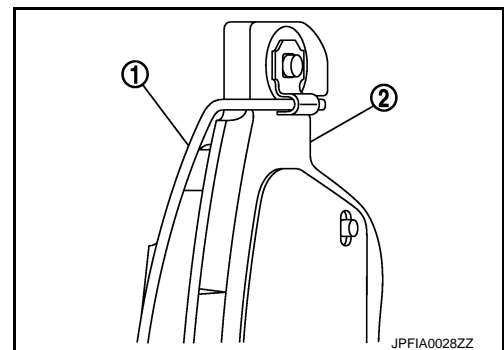

## BRAKE PAD (1 PISTON TYPE) : Inspection and Adjustment

INFOID:000000001832400

### INSPECTION AFTER REMOVAL

Eliminate rust on the pad retainers and the torque member. Replace them if rust is excessively attached.

### ADJUSTMENT AFTER INSTALLATION

#### Brake Burnishing Procedure

Burnish contact surfaces between pads according to following procedure after refinishing or replacing pads, or if a soft pedal occurs at very low mileage.

#### **CAUTION:**

- Be careful of vehicle speed because the brake does not operate easily until pads and disc rotor are securely fitted.
- Only perform this procedure under safe road and traffic conditions. Use extreme caution.

1. Drive vehicle on straight, flat road.
2. Depress brake pedal with the power to stop vehicle within 3 to 5 seconds until the vehicle stops.

# FRONT DISC BRAKE

## < REMOVAL AND INSTALLATION >

3. Drive without depressing brake for a few minutes to cool the brake.
4. Repeat steps 1 to 3 until pad and disc rotor are securely fitted.

### BRAKE PAD (2 PISTON TYPE)

#### BRAKE PAD (2 PISTON TYPE) : Exploded View

INFOID:000000001879590

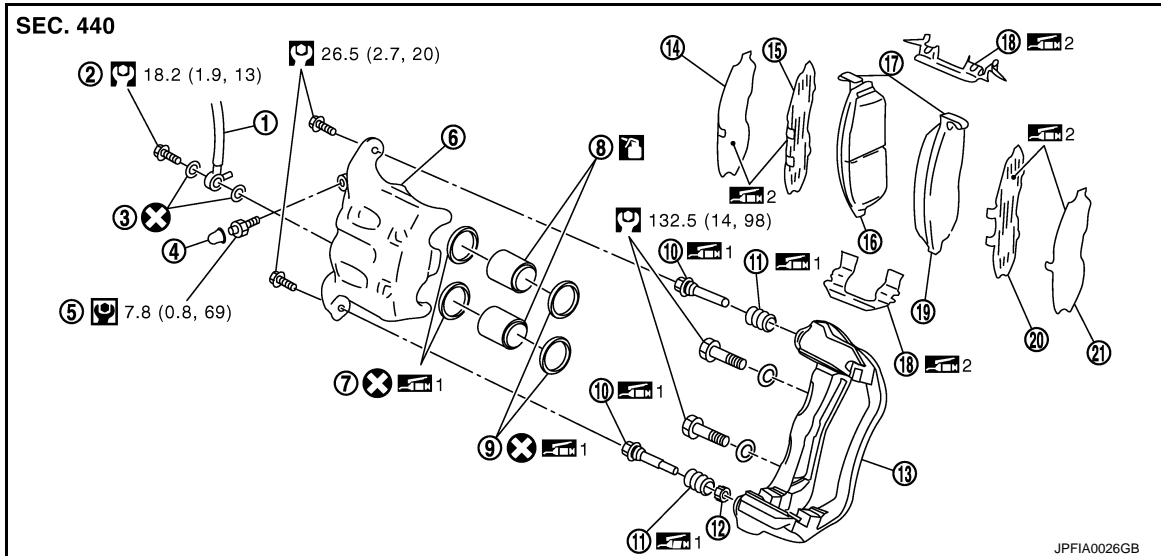

- |                   |                      |                      |
|-------------------|----------------------|----------------------|
| 1. Brake hose     | 2. Union bolt        | 3. Copper washer     |
| 4. Cap            | 5. Bleeder valve     | 6. Cylinder body     |
| 7. Piston seal    | 8. Piston            | 9. Piston boot       |
| 10. Sliding pin   | 11. Sliding pin boot | 12. Bushing          |
| 13. Torque member | 14. Inner shim cover | 15. Inner shim       |
| 16. Inner pad     | 17. Pad wear sensor  | 18. Pad retainer     |
| 19. Outer pad     | 20. Outer shim       | 21. Outer shim cover |

1: Apply rubber grease.

2: Apply copper based brake grease.

3: Apply brake fluid.

Refer to [GI-4, "Components"](#) for symbols not described on the above.

#### BRAKE PAD (2 PISTON TYPE) : Removal and Installation

INFOID:000000001832402

##### REMOVAL

##### **WARNING:**

Clean any dust from the brake caliper and brake pads with a vacuum dust collector. Never blow with compressed air.

##### **CAUTION:**

- Never depress the brake pedal while removing the brake pads because the piston may pop out.
- Never spill or splash brake fluid on the disc rotor.

1. Remove tires with power tool.
2. Remove lower sliding pin bolt.
3. Suspend the cylinder body with suitable wire so that the brake hose will not stretch. Then remove the brake pad from the torque member.

##### **CAUTION:**

- Never deform the pad retainer when removing the pad retainer from the torque member.
- Never damage the piston boot.
- Never drop the brake pads, shims, and the shim covers.

##### INSTALLATION



# FRONT DISC BRAKE

## < REMOVAL AND INSTALLATION >

### **WARNING:**

Clean any dust from the brake caliper and brake pads with a vacuum dust collector. Never blow with compressed air.

### **CAUTION:**

- Never depress the brake pedal while removing the brake pads because the piston may pop out.
- Never spill or splash brake fluid on the disc rotor.

1. Apply Copper based brake grease to the pad retainers before installing it to the torque member if the pad retainers has been removed.

### **CAUTION:**

- Securely assemble the pad retainers so that it will not be lifted up from the torque member.
- Never deform the pad retainers.

2. Apply Copper based brake grease to the mating faces between the shims and the shim covers and install them to the brake pad.

### **CAUTION:**

Always replace the shims together with the shim covers when replacing the brake pad.

3. Install the brake pads to the torque member.

### **CAUTION:**

Both inner and outer pads have a pad return system on the pad retainer. Install pad return lever (1) securely to pad wear sensor (2).

4. Install cylinder body to torque member.

### **CAUTION:**

- Never damage the piston boot.
- In the case of replacing a pad with new one, check a brake fluid level in the reservoir tank because brake fluid returns to master cylinder reservoir tank when pressing piston in.

### **NOTE:**

Use a disc brake piston tool to easily press piston.

5. Install the lower sliding pin bolt and tighten it to the specified torque.
6. Depress the brake pedal several times to check that no drag feel is present for the front disc brake.
7. Install tires.

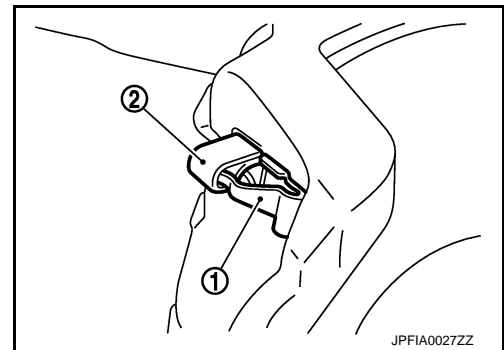

## BRAKE PAD (2 PISTON TYPE) : Inspection and Adjustment

INFOID:000000001832403

### INSPECTION AFTER REMOVAL

Replace the shims and the shim covers if rust is excessively attached.

### ADJUSTMENT AFTER INSTALLATION

#### Brake Burnishing Procedure

Burnish contact surfaces between pads according to following procedure after refinishing or replacing pads, or if a soft pedal occurs at very low mileage.

### **CAUTION:**

- Be careful of vehicle speed because the brake does not operate easily until pads and disc rotor are securely fitted.
- Only perform this procedure under safe road and traffic conditions. Use extreme caution.

1. Drive vehicle on straight, flat road.
2. Depress brake pedal with the power to stop vehicle within 3 to 5 seconds until the vehicle stops.
3. Drive without depressing brake for a few minutes to cool the brake.
4. Repeat steps 1 to 3 until pad and disc rotor are securely fitted.

## BRAKE CALIPER ASSEMBLY (1 PISTON TYPE)

# FRONT DISC BRAKE

< REMOVAL AND INSTALLATION >

## BRAKE CALIPER ASSEMBLY (1 PISTON TYPE) : Exploded View

INFOID:000000001832404

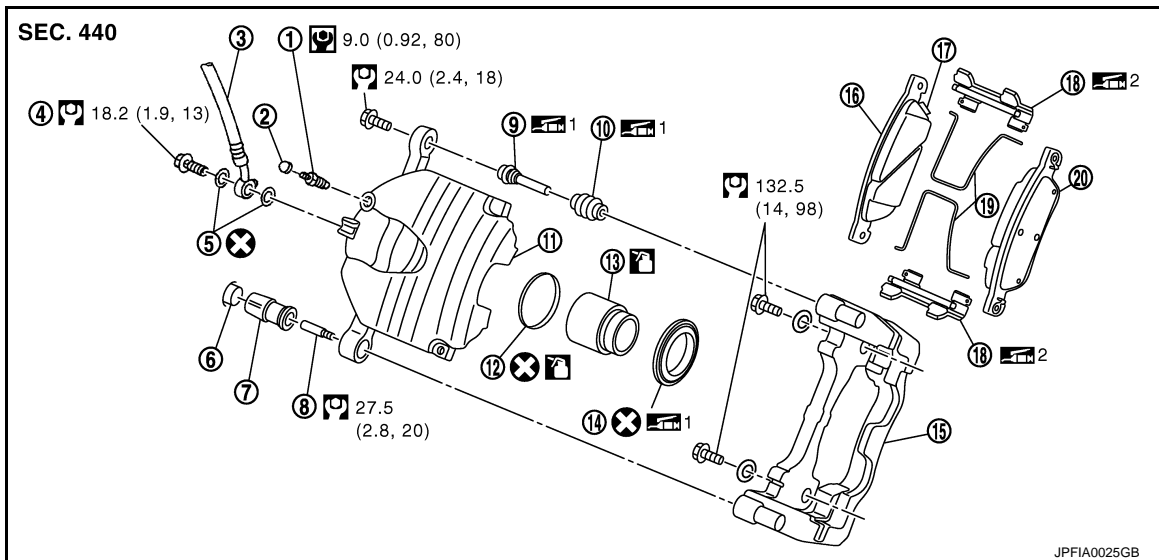

- |                       |                     |                   |
|-----------------------|---------------------|-------------------|
| 1. Bleeder valve      | 2. Cap              | 3. Brake hose     |
| 4. Union bolt         | 5. Copper washer    | 6. Protector      |
| 7. Bushing            | 8. Location pin     | 9. Sliding pin    |
| 10. Sliding pin boot  | 11. Cylinder body   | 12. Piston seal   |
| 13. Piston            | 14. Piston boot     | 15. Torque member |
| 16. Inner pad         | 17. Pad wear sensor | 18. Pad retainer  |
| 19. Pad return spring | 20. Outer pad       |                   |

1: Apply rubber grease.

2: Apply bentonite noise damping brake grease.

: Apply brake fluid.

Refer to [GI-4. "Components"](#) for symbols not described on the above.

## BRAKE CALIPER ASSEMBLY (1 PISTON TYPE) : Removal and Installation

INFOID:000000001832405

### REMOVAL

#### **WARNING:**

**Clean any dust from the brake caliper and brake pads with a vacuum dust collector. Never blow with compressed air.**

#### **CAUTION:**

**Never depress the brake pedal. Brake fluid may splash while removing the brake hose.**

1. Remove tires with power tool.
2. Fix the disc rotor using wheel nuts.
3. Drain brake fluid. Refer to [BR-12. "Draining"](#).

#### **CAUTION:**

**Never spill or splash brake fluid on the disc rotor.**

4. Remove union bolt, and then disconnect brake hose from caliper assembly.

# FRONT DISC BRAKE

## < REMOVAL AND INSTALLATION >

- Remove torque member mounting bolts, and remove brake caliper assembly.  
**CAUTION:**  
**Never drop brake pads and caliper assembly.**
- Remove disc rotor.  
**CAUTION:**
  - Put matching marks on the wheel hub and bearing assembly and the disc rotor before removing the disc rotor.
  - Never drop disc rotor.

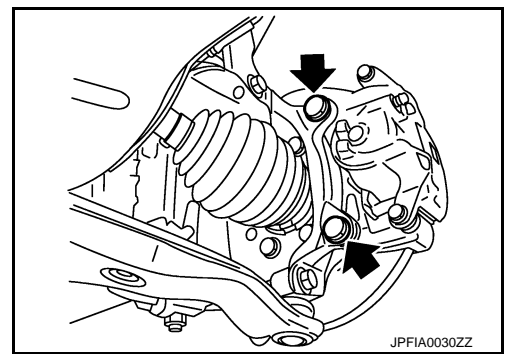

## INSTALLATION

### **WARNING:**

Clean any dust from the brake caliper and brake pads with a vacuum dust collector. Never blow with compressed air.

### **CAUTION:**

Never depress the brake pedal. Brake fluid may splash while removing the brake hose.

- Install disc rotor.  
**CAUTION:**  
**Align the matching marks that have been made during removal when reusing the disc rotor.**
- Install the brake caliper assembly to the vehicle and tighten the torque member mounting bolts to the specified torque.  
**CAUTION:**  
**Never spill or splash any grease and moisture on the brake caliper assembly mounting face, threads, mounting bolts and washers. Wipe out any grease and moisture.**
- Install brake hose to brake caliper assembly, and tighten union bolts to the specified torque.
- Refill with new brake fluid and perform the air bleeding. Refer to [BR-13. "Bleeding Brake System"](#).  
**CAUTION:**
  - Never reuse drained brake fluid.
  - Never spill or splash brake fluid on the disc rotor.
- Check that no drag feel is present for the front disc brake.
- Install tires.

## BRAKE CALIPER ASSEMBLY (1 PISTON TYPE) : Disassembly and Assembly

INFOID:000000001832406

## DISASSEMBLY

### **NOTE:**

The torque member, brake pads, pad return spring and pad retainers never need to be removed when disassembling and assembling the cylinder body.

- Remove the protector and location pin and the sliding pin bolt, and remove the cylinder body from the torque member.  
**CAUTION:**  
**Never drop pads, pad return spring and pad retainers from torque member.**
- Remove sliding pin and sliding pin boot from torque member.
- Place a wooden block as shown in the figure, and blow air from union bolt mounting hole to remove piston and piston boot.  
**CAUTION:**  
**Never get fingers caught in the pistons.**

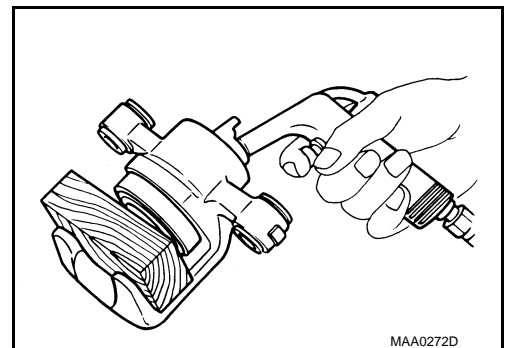

# FRONT DISC BRAKE

## < REMOVAL AND INSTALLATION >

4. Remove piston seal from cylinder body using suitable tool.

**CAUTION:**

**Be careful not to damage a cylinder inner wall.**

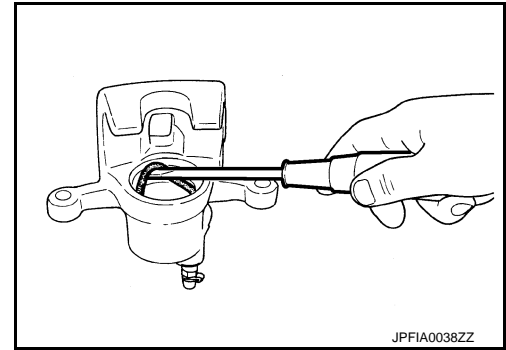

## ASSEMBLY

1. Apply brake fluid to piston seal (1), and install them to cylinder body.

**CAUTION:**

**Never reuse piston seal.**

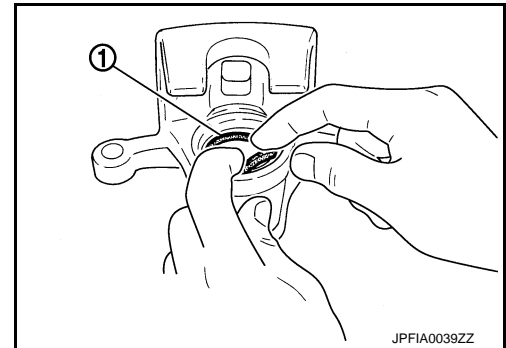

2. Apply rubber grease to piston boot (1). Cover the piston (2) end with piston boot, and then install cylinder side lip on piston boot securely into a groove on cylinder body.

**CAUTION:**

**Never reuse piston boot.**

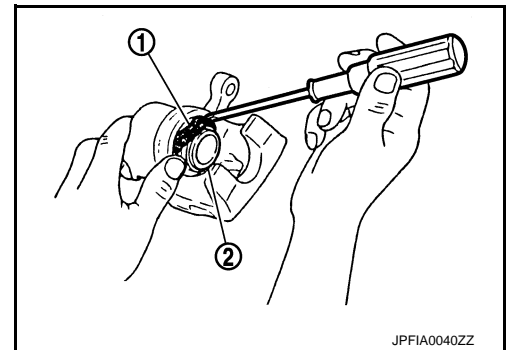

3. Apply brake fluid to piston (1). Push piston into cylinder body by hand and push piston boot (2) piston-side lip into the piston groove.

**CAUTION:**

**Press the piston evenly and vary the pressing point to prevent cylinder inner wall from being rubbed.**

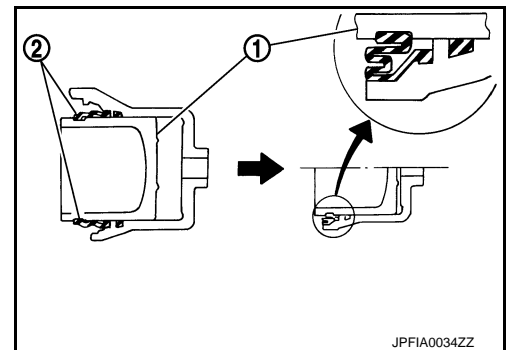

4. Install sliding pin and sliding pin boots to torque member.
5. Install the cylinder body to the torque member and tighten the location pin and sliding pin bolt to the specified torque.
6. Install the protector.

## BRAKE CALIPER ASSEMBLY (1 PISTON TYPE) : Inspection and Adjustment

INFOID:000000001832407

## INSPECTION AFTER DISASSEMBLY

# FRONT DISC BRAKE

## < REMOVAL AND INSTALLATION >

### Cylinder Body

Check the inner wall of the cylinder for rust, wear, cracks or damage. Replace the cylinder if any abnormal condition is detected.

#### **CAUTION:**

**Always clean with new brake fluid. Never clean with mineral oil such as gasoline and light oil.**

### Torque Member

- Check the torque member for wear, cracks or damage. Replace the torque member if any abnormal condition is detected.
- Eliminate rust on the torque member. Replace them if rust is excessively attached.

### Piston

Check the surface of the piston for rust, wear, cracks or damage. Replace the piston if any abnormal condition is detected.

#### **CAUTION:**

**A piston sliding surface is plated. Never polish with sandpaper.**

### Location Pin, Protector and Bushing

Check the location pin, protector and bushing for rust, wear, cracks or damage. Replace the parts if any abnormal condition is detected.

### Sliding Pin and Sliding Pin Boot

Check the sliding pin and sliding boots for rust, wear, cracks or damage. Replace the parts if any abnormal condition is detected.

## ADJUSTMENT AFTER INSTALLATION

### Brake Burnishing Procedure

Burnish contact surfaces between disc rotors and pads according to following procedure after refinishing or replacing disc rotor, or if a soft pedal occurs at very low mileage.

#### **CAUTION:**

- **Be careful of vehicle speed because the brake does not operate easily until pad and disc rotor are securely fitted.**
- **Only perform this procedure under safe road and traffic conditions. Use extreme caution.**

1. Drive vehicle on straight, flat road.
2. Depress brake pedal with the power to stop vehicle within 3 to 5 seconds until the vehicle stops.
3. Drive without depressing brake for a few minutes to cool the brake.
4. Repeat steps 1 to 3 until pad and disc rotor are securely fitted.

## BRAKE CALIPER ASSEMBLY (2 PISTON TYPE)

### BRAKE CALIPER ASSEMBLY (2 PISTON TYPE) : Exploded View

INFOID:000000001832408

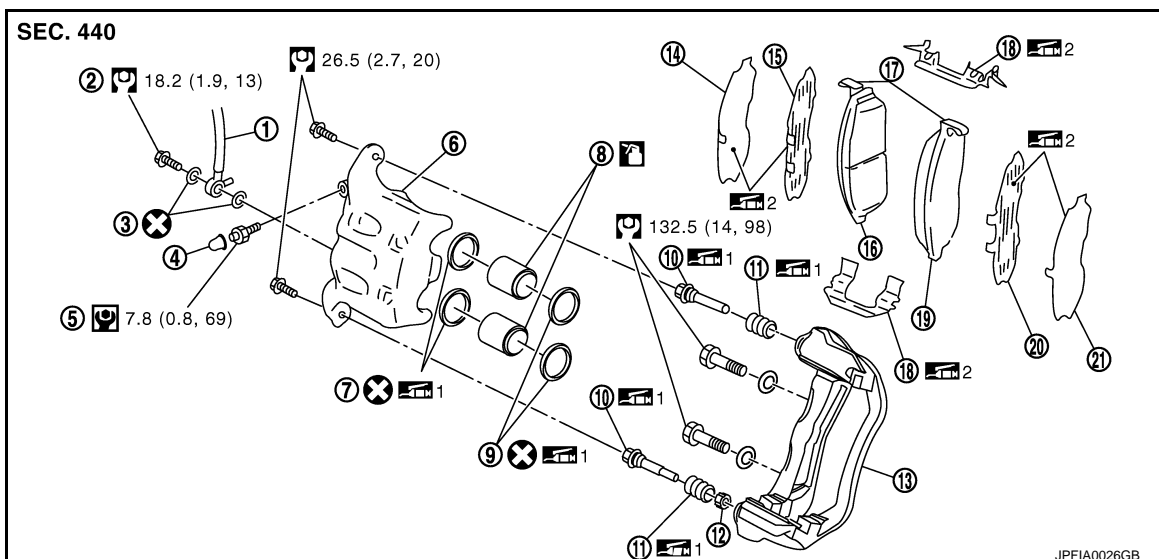



# FRONT DISC BRAKE

## < REMOVAL AND INSTALLATION >

- |                   |                      |                      |
|-------------------|----------------------|----------------------|
| 1. Brake hose     | 2. Union bolt        | 3. Copper washer     |
| 4. Cap            | 5. Bleeder valve     | 6. Cylinder body     |
| 7. Piston seal    | 8. Piston            | 9. Piston boot       |
| 10. Sliding pin   | 11. Sliding pin boot | 12. Bushing          |
| 13. Torque member | 14. Inner shim cover | 15. Inner shim       |
| 16. Inner pad     | 17. Pad wear sensor  | 18. Pad retainer     |
| 19. Outer pad     | 20. Outer shim       | 21. Outer shim cover |

1: Apply rubber grease.

2: Apply copper based brake grease.

: Apply brake fluid.

Refer to [GI-4. "Components"](#) for symbols not described on the above.

## BRAKE CALIPER ASSEMBLY (2 PISTON TYPE) : Removal and Installation

INFOID:000000001832409

### REMOVAL

#### **WARNING:**

**Clean any dust from the brake caliper and brake pads with a vacuum dust collector. Never blow with compressed air.**

#### **CAUTION:**

**Never depress the brake pedal. Brake fluid may splash while removing the brake hose.**

1. Remove tires with power tool.
2. Fix the disc rotor using wheel nuts.
3. Drain brake fluid. Refer to [BR-12. "Draining"](#).

#### **CAUTION:**

**Never spill or splash brake fluid on the disc rotor.**

4. Remove union bolt, and then disconnect brake hose from caliper assembly.
5. Remove torque member mounting bolts, and remove brake caliper assembly.

#### **CAUTION:**

**Never drop brake pad and caliper assembly.**

6. Remove disc rotor.

#### **CAUTION:**

- Put matching marks on the wheel hub and bearing assembly and the disc rotor before removing the disc rotor.
- Never drop disc rotor.

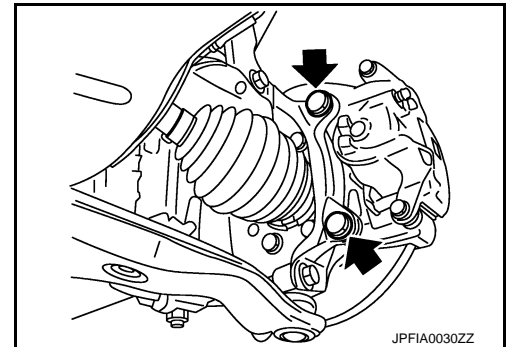

### INSTALLATION

#### **WARNING:**

**Clean any dust from the brake caliper and brake pads with a vacuum dust collector. Never blow with compressed air.**

#### **CAUTION:**

**Never depress the brake pedal. Brake fluid may splash while removing the brake hose.**

1. Install disc rotor.  
**CAUTION:**  
**Align the matching marks that have been made during removal when reusing the disc rotor.**
2. Install the brake caliper assembly to the vehicle and tighten the torque member mounting bolts to the specified torque.  
**CAUTION:**  
**Never spill or splash any grease and moisture on the brake caliper assembly mounting face, threads, mounting bolts and washers. Wipe out any grease and moisture.**
3. Install brake hose to brake caliper assembly, and tighten union bolts to the specified torque.

# FRONT DISC BRAKE

## < REMOVAL AND INSTALLATION >

4. Refill with new brake fluid and perform the air bleeding. Refer to [BR-13. "Bleeding Brake System"](#).  
**CAUTION:**
  - Never reuse drained brake fluid.
  - Never spill or splash brake fluid on the disc rotor.
5. Check that no drag feel is present for the front disc brake.
6. Install tires.

## BRAKE CALIPER ASSEMBLY (2 PISTON TYPE) : Disassembly and Assembly

INFOID:000000001832410

### DISASSEMBLY

#### NOTE:

The torque member, brake pads, shims, shim covers and pad retainers never need to be removed when disassembling and assembling the cylinder body.

1. Remove the sliding pin bolt, and remove the cylinder body from the torque member.

#### CAUTION:

Never drop pads, shims, shim covers and pad retainers from torque member.

2. Remove sliding pins and sliding pin boots from torque member.
3. Place a wooden block as shown in the figure, and blow air from union bolt mounting hole to remove pistons and piston boots.

#### CAUTION:

Never get fingers caught in the pistons.

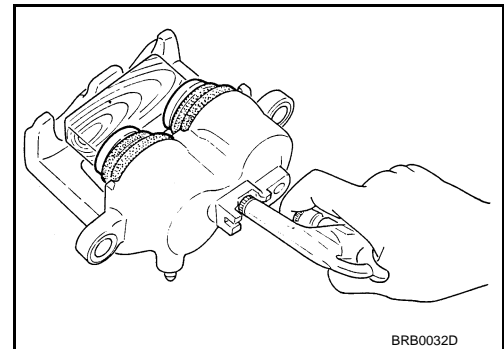

4. Remove piston seal from cylinder body using suitable tool.

#### CAUTION:

Be careful not to damage a cylinder inner wall.

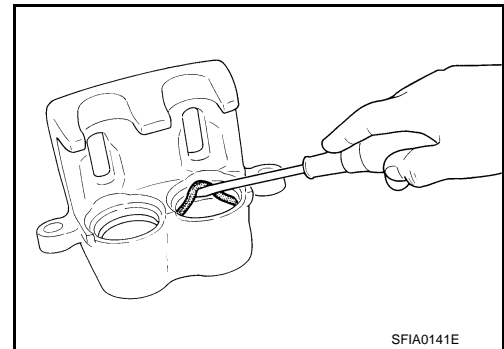

### ASSEMBLY

1. Apply rubber grease to piston seals (1), and install them to cylinder body.

#### CAUTION:

Never reuse piston seals.

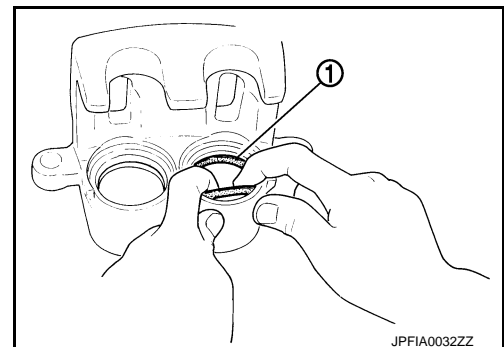



## FRONT DISC BRAKE

### < REMOVAL AND INSTALLATION >

2. Apply rubber grease to piston boots (1). Cover the piston (2) end with piston boot, and then install cylinder side lip on piston boot securely into a groove on cylinder body.

**CAUTION:**

**Never reuse piston boots.**

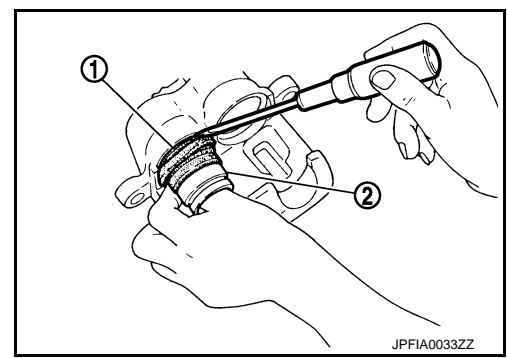

3. Apply brake fluid to pistons (1). Push piston into cylinder body by hand and push piston boot (2) piston-side lip into the piston groove.

**CAUTION:**

**Press the pistons evenly and vary the pressing point to prevent cylinder inner wall from being rubbed.**

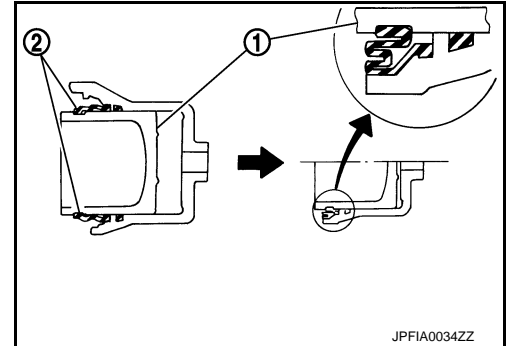

4. Install sliding pins and sliding pin boots to torque member.
5. Install the cylinder body to the torque member and tighten the sliding pin bolts to the specified torque.

### BRAKE CALIPER ASSEMBLY (2 PISTON TYPE) : Inspection and Adjustment

INFOID:000000001832411

#### INSPECTION AFTER DISASSEMBLY

##### Cylinder Body

Check the inner wall of the cylinder for rust, wear, cracks or damage. Replace the cylinder if any abnormal condition is detected.

**CAUTION:**

**Always clean with new brake fluid. Never clean with mineral oil such as gasoline and light oil.**

##### Torque Member

Check the torque member for rust, wear, cracks or damage. Replace the member if any abnormal condition is detected.

##### Pistons

Check the surface of the piston for rust, wear, cracks or damage. Replace the piston if any abnormal condition is detected.

**CAUTION:**

**A piston sliding surface is plated. Never polish with sandpaper.**

##### Sliding Pin and Sliding Pin Boot

Check the sliding pins and sliding boots for rust, wear, cracks or damage. Replace the parts if any abnormal condition is detected.

#### ADJUSTMENT AFTER INSTALLATION

##### Brake Burnishing Procedure

Burnish contact surfaces between disc rotors and pads according to following procedure after refinishing or replacing disc rotor, or if a soft pedal occurs at very low mileage.

**CAUTION:**

- **Be careful of vehicle speed because the brake does not operate easily until pad and disc rotor are securely fitted.**
- **Only perform this procedure under safe road and traffic conditions. Use extreme caution.**

1. Drive vehicle on straight, flat road.



## FRONT DISC BRAKE

### < REMOVAL AND INSTALLATION >

---

2. Depress brake pedal with the power to stop vehicle within 3 to 5 seconds until the vehicle stops.
3. Drive without depressing brake for a few minutes to cool the brake.
4. Repeat steps 1 to 3 until pad and disc rotor are securely fitted.

A

B

C

D

E

**BR**

G

H

I

J

K

L

M

N

O

P

# REAR DISC BRAKE

< REMOVAL AND INSTALLATION >

## REAR DISC BRAKE

### BRAKE PAD (FRONT CALIPER 1 PISTON TYPE)

### BRAKE PAD (FRONT CALIPER 1 PISTON TYPE) : Exploded View

INFOID:000000001879591

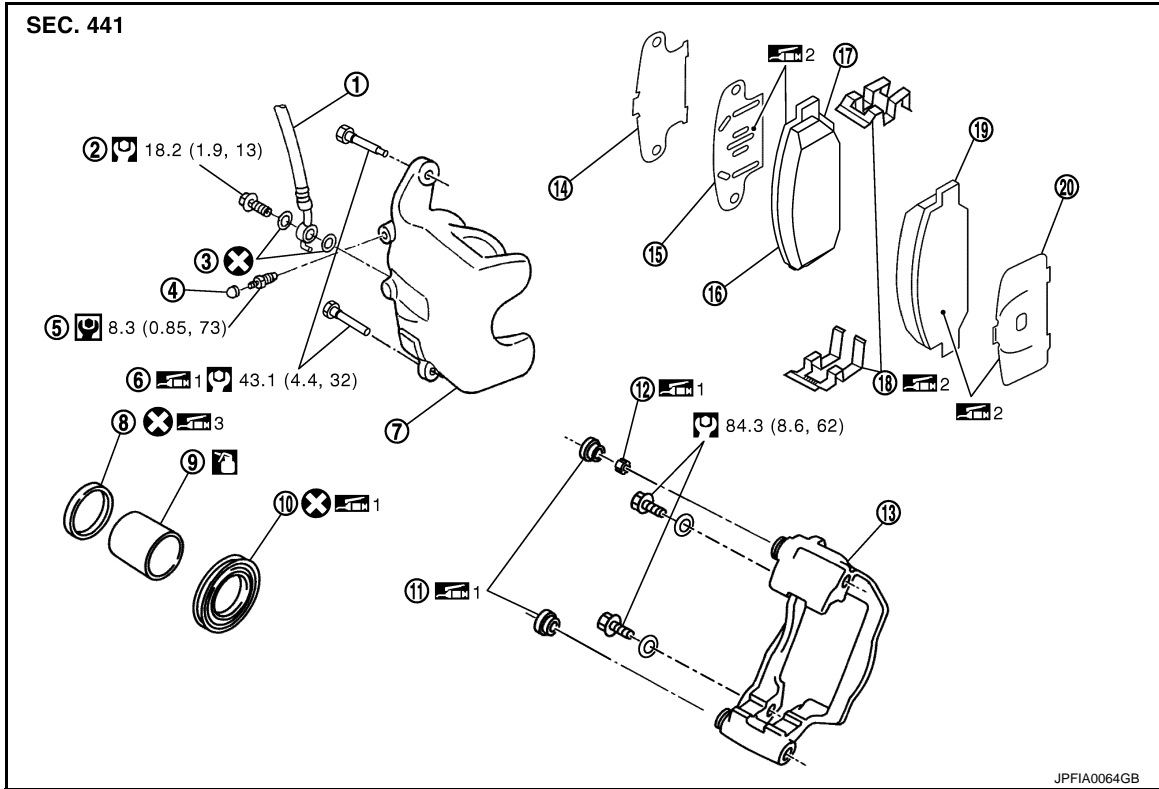

JPFIA0064GB

- |                   |                      |                     |
|-------------------|----------------------|---------------------|
| 1. Brake hose     | 2. Union bolt        | 3. Copper washer    |
| 4. Cap            | 5. Bleeder valve     | 6. Sliding pin bolt |
| 7. Cylinder body  | 8. Piston seal       | 9. Piston           |
| 10. Piston boot   | 11. Sliding pin boot | 12. Bushing         |
| 13. Torque member | 14. Inner shim cover | 15. Inner shim      |
| 16. Inner pad     | 17. Pad wear sensor  | 18. Pad retainer    |
| 19. Outer pad     | 20. Outer shim       |                     |

1: Apply rubber grease.

2: Apply PBC (Poly Butyl Cuprysil) grease or silicone-based grease.

3: Apply polyglycol ether based lubricant.

: Apply brake fluid.

Refer to [GI-4, "Components"](#) for symbols not described on the above.

## BRAKE PAD (FRONT CALIPER 1 PISTON TYPE) : Removal and Installation

INFOID:000000001832413

### REMOVAL

#### **WARNING:**

Clean any dust from the brake caliper and brake pads with a vacuum dust collector. Never blow with compressed air.

#### **CAUTION:**

- Never depress the brake pedal while removing the brake pads or the cylinder body because the piston may pop out.
- Never spill or splash brake fluid on the disc rotor.

# REAR DISC BRAKE

## < REMOVAL AND INSTALLATION >

1. Remove tires with power tool.
2. Remove the upper sliding pin bolt.
3. Suspend the cylinder body with suitable wire so that the brake hose will not stretch. Remove the brake pads from the torque member.

### CAUTION:

- Never deform the pad retainers if removing the pad retainers.
- Never damage the piston boot.
- Never drop the brake pad, shims, and the shim cover.

## INSTALLATION

### WARNING:

Clean any dust from the brake caliper and brake pads with a vacuum dust collector. Never blow with compressed air.

### CAUTION:

- Never depress the brake pedal while removing the brake pads or the cylinder body because the piston may pop out.
- Never spill or splash brake fluid on the disc rotor.

1. Apply PBC (Poly Butyl Cuprysil) grease or silicone-based grease to the pad retainers before installing it to the torque member if the pad retainers has been removed.

### CAUTION:

- Securely assemble the pad retainers so that it will not be lifted up from the torque member.
- Never deform the pad retainers.

2. Apply PBC (Poly Butyl Cuprysil) grease or silicone-based grease to the mating faces between the shims and the shim cover and install them to the brake pad.

### CAUTION:

Always replace the shims together with the shim cover when replacing the brake pad.

3. Install cylinder body and brake pads to torque member.

### CAUTION:

- Never damage the piston boot.
- In the case of replacing a pads with new one, check a brake fluid level in the reservoir tank because brake fluid returns to master cylinder reservoir tank when pressing piston in.

### NOTE:

Use a disc brake piston tool to easily press piston.

4. Install the upper sliding pin bolt and tighten it to the specified torque.
5. Depress the brake pedal several times to check that no drag feel is present for the rear disc brake.
6. Install tires.

## BRAKE PAD (FRONT CALIPER 1 PISTON TYPE) : Inspection and Adjustment

INFOID:000000001832414

## INSPECTION AFTER REMOVAL

Replace the shims and the shim cover if rust is excessively attached.

## ADJUSTMENT AFTER INSTALLATION

### Brake Burnishing Procedure

Burnish contact surfaces between pads according to following procedure after refinishing or replacing pads, or if a soft pedal occurs at very low mileage.

### CAUTION:

- Be careful of vehicle speed because the brake does not operate easily until pad and disc rotor are securely fitted.
- Only perform this procedure under safe road and traffic conditions. Use extreme caution.

1. Drive vehicle on straight, flat road.
2. Depress brake pedal with the power to stop vehicle within 3 to 5 seconds until the vehicle stops.
3. Drive without depressing brake for a few minutes to cool the brake.
4. Repeat steps 1 to 3 until pad and disc rotor are securely fitted.

## BRAKE PAD (FRONT CALIPER 2 PISTON TYPE)

# REAR DISC BRAKE

< REMOVAL AND INSTALLATION >

## BRAKE PAD (FRONT CALIPER 2 PISTON TYPE) : Exploded View

INFOID:000000001879592

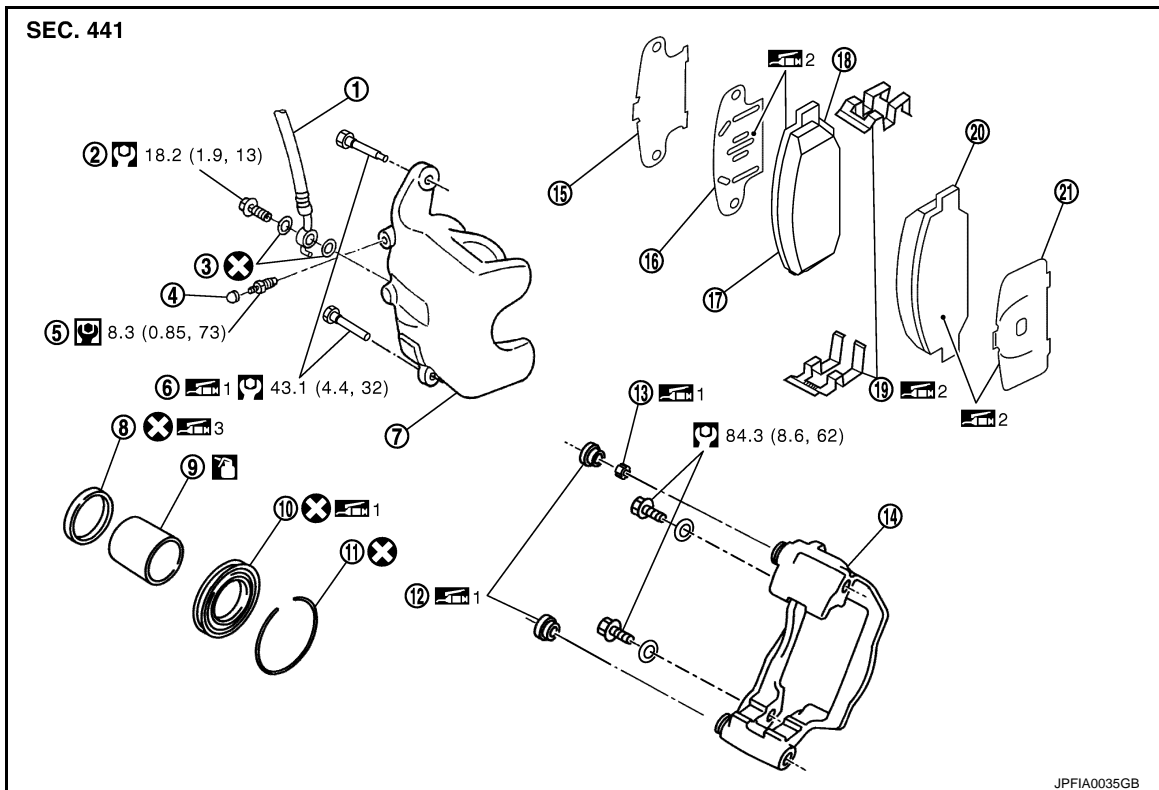

- |                  |                    |                      |
|------------------|--------------------|----------------------|
| 1. Brake hose    | 2. Union bolt      | 3. Copper washer     |
| 4. Cap           | 5. Bleeder valve   | 6. Sliding pin bolt  |
| 7. Cylinder body | 8. Piston seal     | 9. Piston            |
| 10. Piston boot  | 11. Retaining ring | 12. Sliding pin boot |
| 13. Bushing      | 14. Torque member  | 15. Inner shim cover |
| 16. Inner shim   | 17. Inner pad      | 18. Pad wear sensor  |
| 19. Pad retainer | 20. Outer pad      | 21. Outer shim       |

1: Apply rubber grease.

2: Apply PBC (Poly Butyl Cuprysil) grease or silicone-based grease.

3: Apply polyglycol ether based lubricant.

: Apply brake fluid.

Refer to [GI-4. "Components"](#) for symbols not described on the above.

## BRAKE PAD (FRONT CALIPER 2 PISTON TYPE) : Removal and Installation

INFOID:000000001832416

### REMOVAL

#### **WARNING:**

Clean any dust from the brake caliper and brake pads with a vacuum dust collector. Never blow with compressed air.

#### **CAUTION:**

- Never depress the brake pedal while removing the brake pads or the cylinder body because the piston may pop out.
- Never spill or splash brake fluid on the disc rotor.

1. Remove tires with power tool.
2. Remove the upper sliding pin bolt.

# REAR DISC BRAKE

## < REMOVAL AND INSTALLATION >

3. Suspend the cylinder body with a wire so that the brake hose will not stretch. Remove the brake pad from the torque member.  
**CAUTION:**
  - Never deform the pad retainers if removing the pad retainers.
  - Never damage the piston boot.
  - Never drop the brake pad, shims, and the shim cover.

## INSTALLATION

### **WARNING:**

Clean any dust from the brake caliper and brake pads with a vacuum dust collector. Never blow with compressed air.

### **CAUTION:**

- Never depress the brake pedal while removing the brake pads or the cylinder body because the piston may pop out.
- Never spill or splash brake fluid on the disc rotor.

1. Apply PBC (Poly Butyl Cuprysil) grease or silicone-based grease to the pad retainers before installing it to the torque member if the pad retainers has been removed.

### **CAUTION:**

- Securely assemble the pad retainers so that it will not be lifted up from the torque member.
- Never deform the pad retainers.

2. Apply PBC (Poly Butyl Cuprysil) grease or silicone-based grease to the mating faces between the shims and the shim cover and install them to the brake pad.

### **CAUTION:**

Always replace the shims together with the shim cover when replacing the brake pad.

3. Install cylinder body and brake pads to torque member.

### **CAUTION:**

- Never damage the piston boot.
- In the case of replacing a pad with new one, check a brake fluid level in the reservoir tank because brake fluid returns to master cylinder reservoir tank when pressing piston in.

### **NOTE:**

Use a disc brake piston tool to easily press piston.

4. Install the upper sliding pin bolt and tighten it to the specified torque.
5. Depress the brake pedal several times to check that no drag feel is present for the rear disc brake.
6. Install tires.

## BRAKE PAD (FRONT CALIPER 2 PISTON TYPE) : Inspection and Adjustment

INFOID:000000001832417

## INSPECTION AFTER REMOVAL

Replace the shims and the shim cover if rust is excessively attached.

## ADJUSTMENT AFTER INSTALLATION

### Brake Burnishing Procedure

Burnish contact surfaces between pads according to following procedure after refinishing or replacing pads, or if a soft pedal occurs at very low mileage.

### **CAUTION:**

- Be careful of vehicle speed because the brake does not operate easily until pad and disc rotor are securely fitted.
- Only perform this procedure under safe road and traffic conditions. Use extreme caution.

1. Drive vehicle on straight, flat road.
2. Depress brake pedal with the power to stop vehicle within 3 to 5 seconds until the vehicle stops.
3. Drive without depressing brake for a few minutes to cool the brake.
4. Repeat steps 1 to 3 until pad and disc rotor are securely fitted.

## BRAKE CALIPER ASSEMBLY (FRONT CALIPER 1 PISTON TYPE)

# REAR DISC BRAKE

< REMOVAL AND INSTALLATION >

## BRAKE CALIPER ASSEMBLY (FRONT CALIPER 1 PISTON TYPE) : Exploded View

INFOID:000000001832418

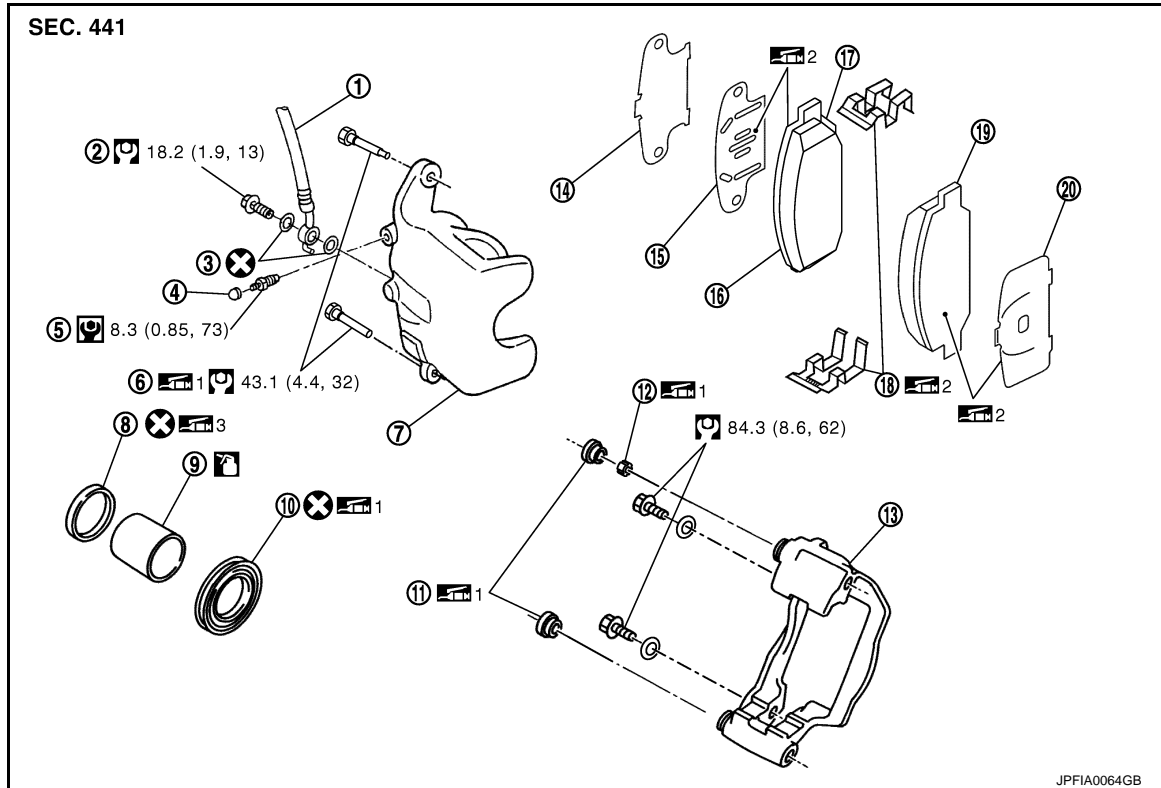

- |                   |                      |                     |
|-------------------|----------------------|---------------------|
| 1. Brake hose     | 2. Union bolt        | 3. Copper washer    |
| 4. Cap            | 5. Bleeder valve     | 6. Sliding pin bolt |
| 7. Cylinder body  | 8. Piston seal       | 9. Piston           |
| 10. Piston boot   | 11. Sliding pin boot | 12. Bushing         |
| 13. Torque member | 14. Inner shim cover | 15. Inner shim      |
| 16. Inner pad     | 17. Pad wear sensor  | 18. Pad retainer    |
| 19. Outer pad     | 20. Outer shim       |                     |

1: Apply rubber grease.

2: Apply PBC (Poly Butyl Cuprysil) grease or silicone-based grease.

3: Apply polyglycol ether based lubricant.

: Apply brake fluid.

Refer to [GI-4, "Components"](#) for symbols not described on the above.

## BRAKE CALIPER ASSEMBLY (FRONT CALIPER 1 PISTON TYPE) : Removal and Installation

INFOID:000000001832419

### REMOVAL

#### **WARNING:**

Clean any dust from the brake caliper and brake pads with a vacuum dust collector. Never blow with compressed air.

#### **CAUTION:**

Never depress the brake pedal. Brake fluid may splash while removing the brake hose.

1. Remove tires with power tool.
2. Fix the disc rotor using wheel nuts.
3. Drain brake fluid. Refer to [BR-12, "Draining"](#).

#### **CAUTION:**

# REAR DISC BRAKE

## < REMOVAL AND INSTALLATION >

**Never spill or splash brake fluid on the disc rotor.**

4. Remove union bolt (1) and then disconnect brake hose (2) from caliper assembly.
5. Remove torque member mounting bolts, and remove brake caliper assembly.

**CAUTION:**

**Never drop brake pads and caliper assembly.**

6. Remove disc rotor.

**CAUTION:**

- Put matching marks on the wheel hub and bearing assembly and the disc rotor before removing the disc rotor.
- Never drop disc rotor.

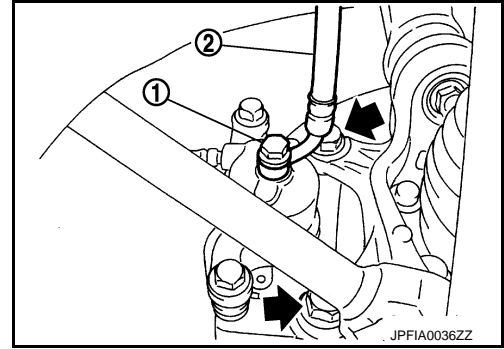

## INSTALLATION

**WARNING:**

Clean any dust from the brake caliper and brake pads with a vacuum dust collector. Never blow with compressed air.

**CAUTION:**

Never depress the brake pedal. Brake fluid may splash while removing the brake hose.

1. Install disc rotor.

**CAUTION:**

Align the matching marks that have been made during removal when reusing the disc rotor.

2. Install the brake caliper assembly to the vehicle and tighten the torque member mounting bolts to the specified torque.

**CAUTION:**

Never spill or splash any grease and moisture on the brake caliper assembly mounting face, threads, mounting bolts, and washers. Wipe out any grease and moisture.

3. Install brake hose to brake caliper assembly, and tighten union bolts to the specified torque.
4. Refill with new brake fluid and perform the air bleeding. Refer to [BR-13, "Bleeding Brake System"](#).

**CAUTION:**

- Never reuse drained brake fluid.
- Never spill or splash brake fluid on the disc rotor.

5. Check that no drag feel is present for the rear disc brake.
6. Install tires.

## BRAKE CALIPER ASSEMBLY (FRONT CALIPER 1 PISTON TYPE) : Disassembly and Assembly

INFOID:000000001832420

### DISASSEMBLY

**NOTE:**

The torque member, brake pads, shims, shim cover and pad retainers never need to be removed when disassembling and assembling the cylinder body.

1. Remove the sliding pin bolt and remove the cylinder body from the torque member.

**CAUTION:**

**Never drop pads, shims, shim cover and pad retainers from torque member.**

2. Remove sliding pin boots from torque member.
3. Place a wooden block as shown in the figure, and blow air from union bolt mounting hole to remove piston and piston boot.

**CAUTION:**

**Never get fingers caught in the piston.**

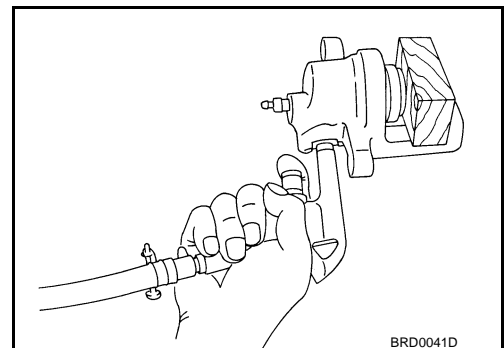

## REAR DISC BRAKE

### < REMOVAL AND INSTALLATION >

4. Remove piston seal from cylinder body using suitable tool.

**CAUTION:**

**Be careful not to damage a cylinder inner wall.**

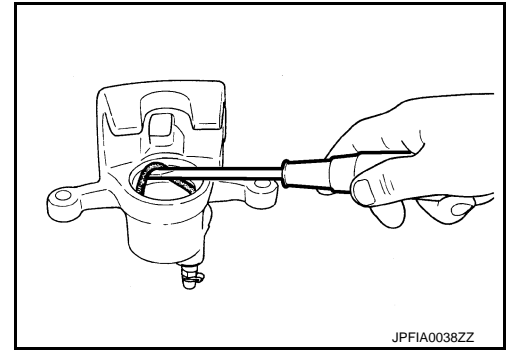

### ASSEMBLY

1. Apply rubber grease to piston seal (1), and install them to cylinder body.

**CAUTION:**

**Never reuse piston seal.**

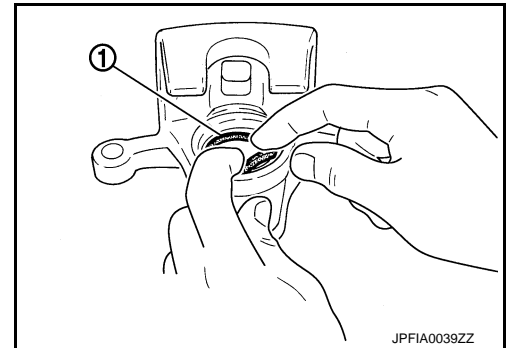

2. Apply rubber grease to piston boot (1). Cover the piston (2) end with the piston boot, and then install cylinder side lip on the piston boot securely into the groove on cylinder body.

**CAUTION:**

**Never reuse piston boot.**

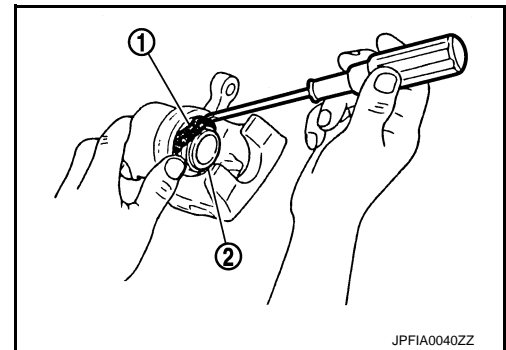

3. Apply brake fluid to piston (1). Push piston into cylinder body by hand and push piston boot (2) piston side lip into the piston groove.

**CAUTION:**

**Press the piston evenly and vary the pressing point to prevent cylinder inner wall from being rubbed.**

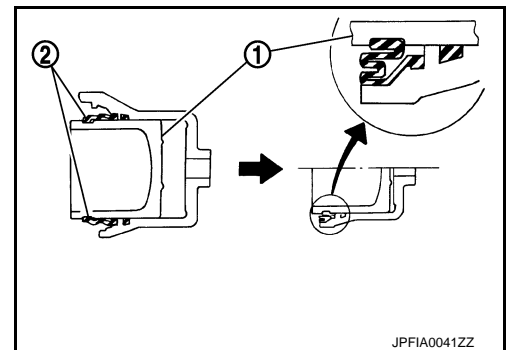

4. Install sliding pin boot to torque member.

5. Install the cylinder body to the torque member and tighten the sliding pin bolt to the specified torque.

## BRAKE CALIPER ASSEMBLY (FRONT CALIPER 1 PISTON TYPE) : Inspection and Adjustment

INFOID:000000001832421

### INSPECTION AFTER DISASSEMBLY

Cylinder Body



## REAR DISC BRAKE

### < REMOVAL AND INSTALLATION >

Check the inner wall of the cylinder for rust, wear, cracks or damage. Replace the cylinder if any abnormal condition is detected.

**CAUTION:**

**Always clean with new brake fluid. Never clean with mineral oil such as gasoline and light oil.**

Torque Member

Check the torque member for rust, wear, cracks or damage. Replace the member if any abnormal condition is detected.

Piston

Check the piston for rust, wear, cracks or damage. Replace the piston if any abnormal condition is detected.

**CAUTION:**

**A piston sliding surface is plated. Never polish with sandpaper.**

Sliding Pin Bolt and Sliding Pin Boot

Check the sliding pin bolts and sliding pin boots for rust, wear, cracks or damage. Replace the parts if any abnormal condition is detected.

### ADJUSTMENT AFTER INSTALLATION

Brake Burnishing Procedure

Burnish contact surfaces between disc rotors and pads according to the following procedure after refinishing or replacing disc rotor, or if a soft pedal occurs at very low mileage.

**CAUTION:**

- **Be careful of vehicle speed because the brake does not operate easily until pad and disc rotor are securely fitted.**
  - **Only perform this procedure under safe road and traffic conditions. Use extreme caution.**
1. Drive vehicle on straight, flat road.
  2. Depress brake pedal with the power to stop vehicle within 3 to 5 seconds until the vehicle stops.
  3. Drive without depressing brake for a few minutes to cool the brake.
  4. Repeat steps 1 to 3 until pad and disc rotor are securely fitted.

### BRAKE CALIPER ASSEMBLY (FRONT CALIPER 2 PISTON TYPE)

A  
B  
C  
D  
E  
BR  
G  
H  
I  
J  
K  
L  
M  
N  
O  
P

# REAR DISC BRAKE

< REMOVAL AND INSTALLATION >

## BRAKE CALIPER ASSEMBLY (FRONT CALIPER 2 PISTON TYPE) : Exploded View

INFOID:000000001832422

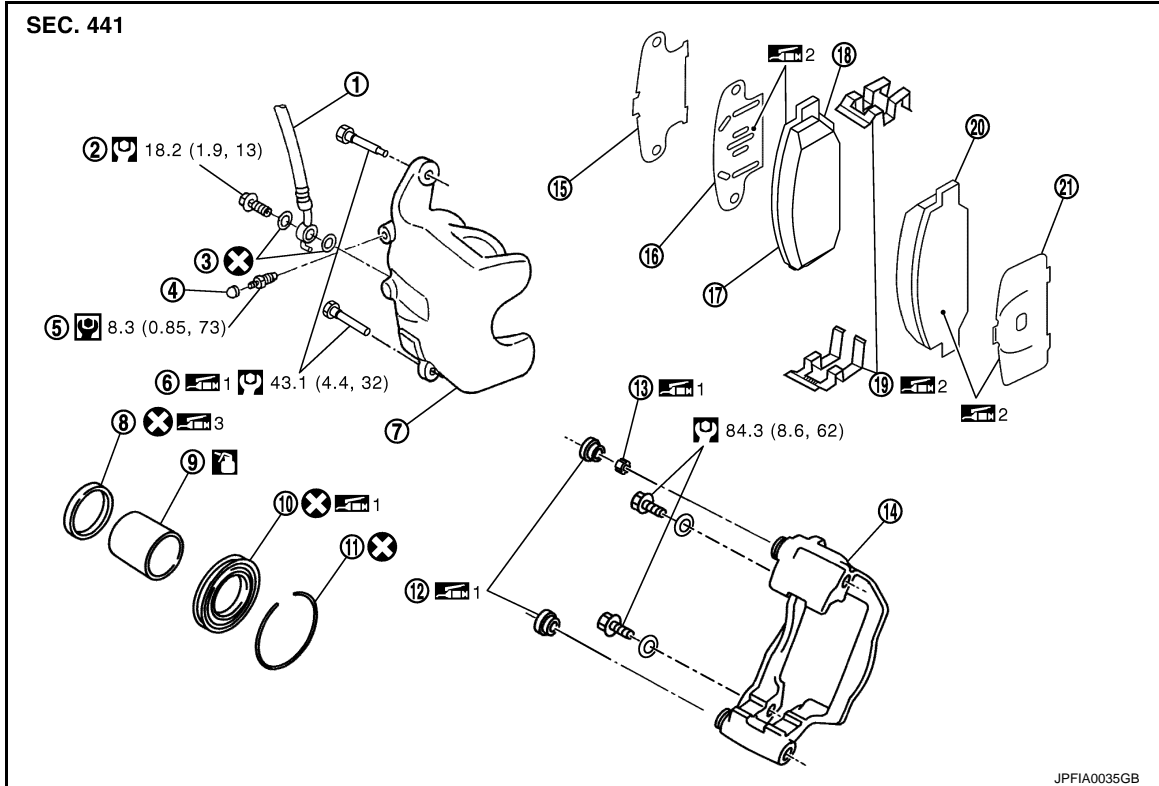

- |                  |                    |                      |
|------------------|--------------------|----------------------|
| 1. Brake hose    | 2. Union bolt      | 3. Copper washer     |
| 4. Cap           | 5. Bleeder valve   | 6. Sliding pin bolt  |
| 7. Cylinder body | 8. Piston seal     | 9. Piston            |
| 10. Piston boot  | 11. Retaining ring | 12. Sliding pin boot |
| 13. Bushing      | 14. Torque member  | 15. Inner shim cover |
| 16. Inner shim   | 17. Inner pad      | 18. Pad wear sensor  |
| 19. Pad retainer | 20. Outer pad      | 21. Outer shim       |

 1: Apply rubber grease.

 2: Apply PBC (Poly Butyl Cuprysil) grease or silicone-based grease.

 3: Apply polyglycol ether based lubricant.

 : Apply brake fluid.

Refer to [GI-4, "Components"](#) for symbols not described on the above.

## BRAKE CALIPER ASSEMBLY (FRONT CALIPER 2 PISTON TYPE) : Removal and Installation

INFOID:000000001832423

### REMOVAL

#### **WARNING:**

Clean any dust from the brake caliper and brake pads with a vacuum dust collector. Never blow with compressed air.

#### **CAUTION:**

Never depress the brake pedal. Brake fluid may splash while removing the brake hose.

1. Remove tires with power tool.
2. Fix the disc rotor using wheel nuts.
3. Drain brake fluid. Refer to [BR-12, "Draining"](#).

#### **CAUTION:**

# REAR DISC BRAKE

## < REMOVAL AND INSTALLATION >

**Never spill or splash brake fluid on the disc rotor.**

4. Remove union bolt (1) and then disconnect brake hose (2) from caliper assembly.
5. Remove torque member mounting bolts, and remove brake caliper assembly.

**CAUTION:**

**Never drop brake pad and caliper assembly.**

6. Remove disc rotor.

**CAUTION:**

- Put matching marks on the wheel hub and bearing assembly and the disc rotor before removing the disc rotor.
- Never drop disc rotor.

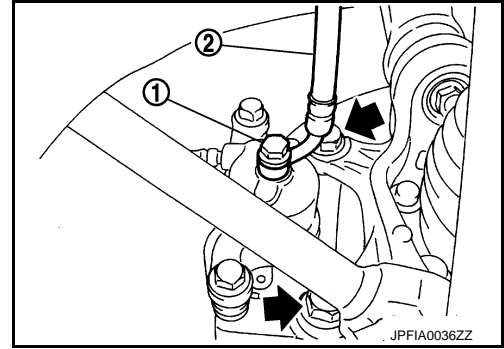

## INSTALLATION

**WARNING:**

Clean any dust from the brake caliper and brake pads with a vacuum dust collector. Never blow with compressed air.

**CAUTION:**

Never depress the brake pedal. Brake fluid may splash while removing the brake hose.

1. Install disc rotor.

**CAUTION:**

Align the matching marks that have been made during removal when reusing the disc rotor.

2. Install the brake caliper assembly to the vehicle and tighten the torque member mounting bolts to the specified torque.

**CAUTION:**

Never spill or splash any grease and moisture on the brake caliper assembly mounting face, threads, mounting bolts, and washers. Wipe out any grease and moisture.

3. Install brake hose to brake caliper assembly, and tighten union bolts to the specified torque.
4. Refill with new brake fluid and perform the air bleeding. Refer to [BR-13, "Bleeding Brake System"](#).

**CAUTION:**

- Never reuse drained brake fluid.
- Never spill or splash brake fluid on the disc rotor.

5. Check that no drag feel is present for the rear disc brake.
6. Install tires.

## BRAKE CALIPER ASSEMBLY (FRONT CALIPER 2 PISTON TYPE) : Disassembly and Assembly

INFOID:000000001832424

### DISASSEMBLY

**NOTE:**

The torque member, brake pads, shims, shim cover and pad retainers never need to be removed when disassembling and assembling the cylinder body.

1. Remove the sliding pin bolts and remove the cylinder body from the torque member.

**CAUTION:**

**Never drop pads, shims, shim cover and pad retainers from torque member.**

2. Remove sliding pin boots from torque member.
3. Remove retaining ring (1) from cylinder body using suitable tool as shown in the figure.

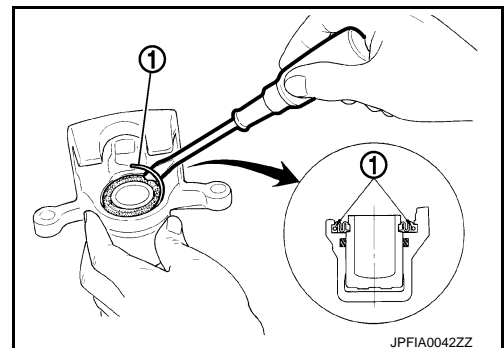

## REAR DISC BRAKE

### < REMOVAL AND INSTALLATION >

- Place a wooden block as shown in the figure, and blow air from union bolt mounting hole to remove piston and piston boot.

**CAUTION:**

**Never get fingers caught in the piston.**

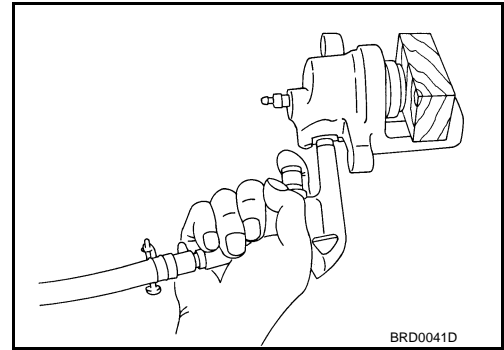

- Remove piston seal from cylinder body using suitable tool.

**CAUTION:**

**Be careful not to damage a cylinder inner wall.**

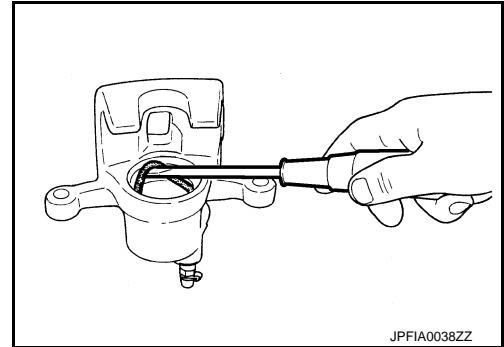

### ASSEMBLY

- Apply rubber grease to piston seal (1), and install them to cylinder body.

**CAUTION:**

**Never reuse piston seal.**

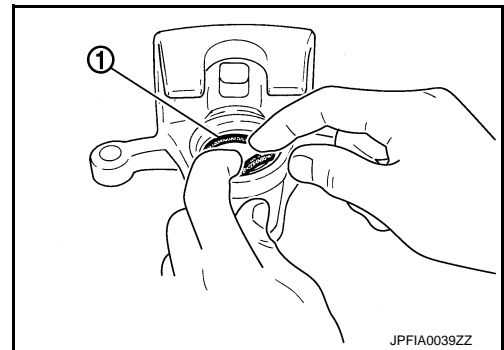

- Apply rubber grease to piston boot (1). Cover the piston (2) end with the piston boot, and then install cylinder side lip on the piston boot securely into the groove on cylinder body.

**CAUTION:**

**Never reuse piston boot.**

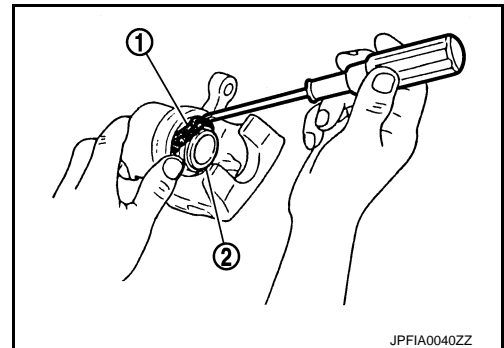

# REAR DISC BRAKE

## < REMOVAL AND INSTALLATION >

3. Apply brake fluid to piston (1). Push piston into cylinder body by hand and push piston boot (2) piston side lip into the piston groove.

**CAUTION:**

**Press the piston evenly and vary the pressing point to prevent cylinder inner wall from being rubbed.**

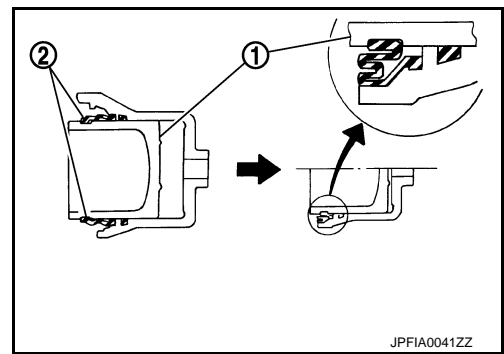

4. Secure piston boot with retaining ring (1).

**CAUTION:**

- **Make sure that boot is securely engaged in the groove on cylinder body.**
- **Never reuse retainer ring.**

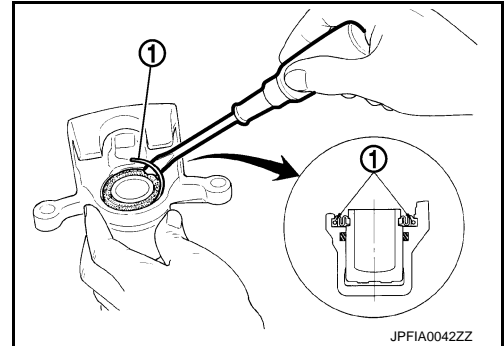

5. Install sliding pin boot to torque member.

6. Install the cylinder body to the torque member and tighten the sliding pin bolt to the specified torque.

## BRAKE CALIPER ASSEMBLY (FRONT CALIPER 2 PISTON TYPE) : Inspection and Adjustment

INFOID:000000001832425

### INSPECTION AFTER DISASSEMBLY

#### Cylinder Body

Check the inner wall of the cylinder for rust, wear, cracks or damage. Replace the cylinder if any abnormal condition is detected.

**CAUTION:**

**Always clean with new brake fluid. Never clean with mineral oil such as gasoline and light oil.**

#### Torque Member

Check the torque member for rust, wear, cracks or damage. Replace the member if any abnormal condition is detected.

#### Piston

Check the piston for rust, wear, cracks or damage. Replace the piston if any abnormal condition is detected.

**CAUTION:**

**A piston sliding surface is plated. Never polish with sandpaper.**

#### Sliding Pin Bolt and Sliding Pin Boot

Check the sliding pin bolts and sliding pin boots for rust, wear, cracks or damage. Replace the parts if any abnormal condition is detected.

### ADJUSTMENT AFTER INSTALLATION

#### Brake Burnishing Procedure

Burnish contact surfaces between disc rotors and pads according to the following procedure after refinishing or replacing disc rotor, or if a soft pedal occurs at very low mileage.

**CAUTION:**

- **Be careful of vehicle speed because the brake does not operate easily until pad and disc rotor are securely fitted.**
- **Only perform this procedure under safe road and traffic conditions. Use extreme caution.**

1. Drive vehicle on straight, flat road.

## REAR DISC BRAKE

### < REMOVAL AND INSTALLATION >

---

2. Depress brake pedal with the power to stop vehicle within 3 to 5 seconds until the vehicle stops.
3. Drive without depressing brake for a few minutes to cool the brake.
4. Repeat steps 1 to 3 until pad and disc rotor are securely fitted.

## SERVICE DATA AND SPECIFICATIONS (SDS)

< SERVICE DATA AND SPECIFICATIONS (SDS)

# SERVICE DATA AND SPECIFICATIONS (SDS)

## SERVICE DATA AND SPECIFICATIONS (SDS)

### General Specifications

INFOID:000000001832426

#### FRONT CALIPER 1 PISTON TYPE

Unit: mm (in)

Front brake	Cylinder bore diameter	57.15 (2.250)
	Pad length × width × thickness	116.1 × 51.7 × 10.3 (4.57 × 2.035 × 0.406)
	Rotor outer diameter × thickness	330 × 32.0 (12.99 × 1.260)
Rear brake	Cylinder bore diameter	38.1 (1.500)
	Pad length × width × thickness	83.0 × 33.0 × 8.5 (3.268 × 1.299 × 0.335)
	Rotor outer diameter × thickness	330 × 16.0 (12.99 × 0.630)
Master cylinder	Cylinder bore diameter	23.8 (15/16)
Control valve	Valve type	Electric brake force distribution
Brake booster	Diaphragm diameter	255 (10)
Recommended brake fluid		DOT 3

#### FRONT CALIPER 2 PISTON TYPE

Unit: mm (in)

Front brake	Cylinder bore diameter	45 (1.772) × 2	
	Pad length × width × thickness	132 × 50.0 × 11.0 (5.20 × 1.969 × 0.433)	
	Rotor outer diameter × thickness	320 × 28.0 (12.60 × 1.102)	
Rear brake	Cylinder bore diameter	42.86 (1.687)	
	Pad length × width × thickness	83.0 × 33.0 × 8.5 (3.268 × 1.299 × 0.335)	
	Rotor outer diameter × thickness	308 × 16.0 (12.13 × 0.630)	
Master cylinder	Cylinder bore diameter	25.4 (1)	
Control valve	Valve type	Electric brake force distribution	
Brake booster	Diaphragm diameter	2WD models	255 (10)
		AWD models	Primary: 230 (9)
			Secondary: 205 (8)
Recommended brake fluid		DOT 3	

### Brake Pedal

INFOID:000000001832427

Unit: mm (in)

Brake pedal height (H1)	171.5 – 181.5 (6.75 – 7.15)
Clearance (C1) between ASCD brake switch threaded end and the stopper rubber	0 – 0.6 (0 – 0.024)
Clearance (C2) between the stop lamp switch threaded end and the stopper rubber	0.74 – 1.96 (0.0291 – 0.0772)
Brake pedal play (A)	2.0 – 8.0 (0.079 – 0.315)
Brake pedal shaky fitting (B)	0 – 1.4 (0.0 – 0.055)
Depressed brake pedal height (H2) [Depressing 490 N (50 kg, 110 lb) while turning the engine ON]	124.0 (4.88) or more

### Brake Booster

INFOID:000000001832428

Vacuum type

Unit: mm (in)

Input rod length (B)	129.5 (5.10)
----------------------	--------------

# SERVICE DATA AND SPECIFICATIONS (SDS)

## < SERVICE DATA AND SPECIFICATIONS (SDS)

### Front Disc Brake

INFOID:000000001832429

#### FRONT CALIPER 1 PISTON TYPE

Unit: mm (in)

Brake pad	Standard thickness	10.3 (0.406)
	Wear limit thickness	2.0 (0.079)
Disc rotor	Standard thickness	32.0 (1.260)
	Wear limit thickness	30.0 (1.181)
	Thickness variation (measured at 8 positions)	0.015 (0.0006)
	Runout limit (with it attached to the vehicle)	0.035 (0.0014)

#### FRONT CALIPER 2 PISTON TYPE

Unit: mm (in)

Brake pad	Standard thickness	11.0 (0.433)
	Wear limit thickness	2.0 (0.079)
Disc rotor	Standard thickness	28.0 (1.102)
	Wear limit thickness	26.0 (1.024)
	Thickness variation (measured at 8 positions)	0.015 (0.0006)
	Runout limit (with it attached to the vehicle)	0.035 (0.0014)

### Rear Disc Brake

INFOID:000000001832430

#### FRONT CALIPER 1 PISTON TYPE

Unit: mm (in)

Brake pad	Standard thickness	8.5 (0.335)
	Wear limit thickness	2.0 (0.079)
Disc rotor	Standard thickness	16.0 (0.631)
	Wear limit thickness	15.0 (0.591)
	Thickness variation (measured at 8 positions)	0.015 (0.0006)
	Runout limit (with it attached to the vehicle)	0.055 (0.0022)

#### FRONT CALIPER 2 PISTON TYPE

Unit: mm (in)

Brake pad	Standard thickness	8.5 (0.335)
	Wear limit thickness	2.0 (0.079)
Disc rotor	Standard thickness	16.0 (0.631)
	Wear limit thickness	14.0 (0.551)
	Thickness variation (measured at 8 positions)	0.015 (0.0006)
	Runout limit (with it attached to the vehicle)	0.055 (0.0022)